

YETI AS-RsL

OWNER'S MANUAL

Assembly Instructions, Shock Setup, Cable Routing, Etc.



YETI CYCLES

600 Corporate Circle, Unit D

Golden, CO

USA

p.303-278-6909 / 888-576-9384

www.yeticycles.com

Table of Contents

Brand Overview	4
Frame Features	6
Geometry	8
Maintenance Schedule	10
Bike Setup Overview	12
› Shock Setup FOX RP3	14
› Quick Start Guide	15
› Cable Routing	16
Assembly Overview	18
› Assembly	20
› Disassembly Tips	24
Exploded Views	26
Part List	28
Warranty	32
Contact Information	33

Overview

Congratulations on your purchase of a new Yeti bicycle. We are confident your new bicycle will exceed your expectations for value, performance and ride quality. Each frameset and component has been custom specified and designed to enhance your riding experience. Whether you are a beginner cyclist or a seasoned-pro, Yeti bicycles will provide endless hours of two-wheeled fun.

GENERAL INFORMATION

This model-specific manual is designed to be used in conjunction with the general Yeti Owner's Manual and the manuals supplied by the suspension manufacturers. If you did not receive the Yeti Owner's Manual or the manual provided by the suspension manufacturer, download the materials off the Internet, or contact your dealer.

Bicycling can be a hazardous activity even under the best of circumstances. Proper maintenance of your bicycle is your responsibility and when done properly helps reduce the risk of injury and damage to your bicycle. This manual outlines basic setup and maintenance recommendations of your new Yeti. Because it is impossible to anticipate every situation or condition that may occur during the assembly, setup and maintenance of your bicycle, Yeti recommends that all service and repairs be

assembly, setup, and maintenance of your bicycle. Yeti recommends that all service and repairs be performed by an authorized Yeti Dealer.

This manual contains many "Warnings" and "Cautions" concerning the consequences of failure to maintain or inspect your bicycle. The combination of the safety alert symbol and the word "Warning" indicates a potentially hazardous situation in which, if not avoided, could result in serious injury or death. The combination of the safety alert symbol and the word "Caution" indicates a potentially hazardous situation in which, if not avoided may result in minor injuries or damage to your bicycle or a component of your bicycle. Be sure to read and understand all of the Warnings and Cautions.



Warning: Make sure you review and understand the warnings, instructions, and content of this manual and accompany manuals for your bicycle.



Warning: Technological advances have made bicycles and bicycle components more complex, and the pace of innovation is increasing. It is impossible for this manual or the accompanying manuals to provide all the information required to properly repair and/or maintain your bicycle. In order to help minimize the chances of an injury, it is critical for you to have work performed by an authorized Yeti retailer.



Frame Features

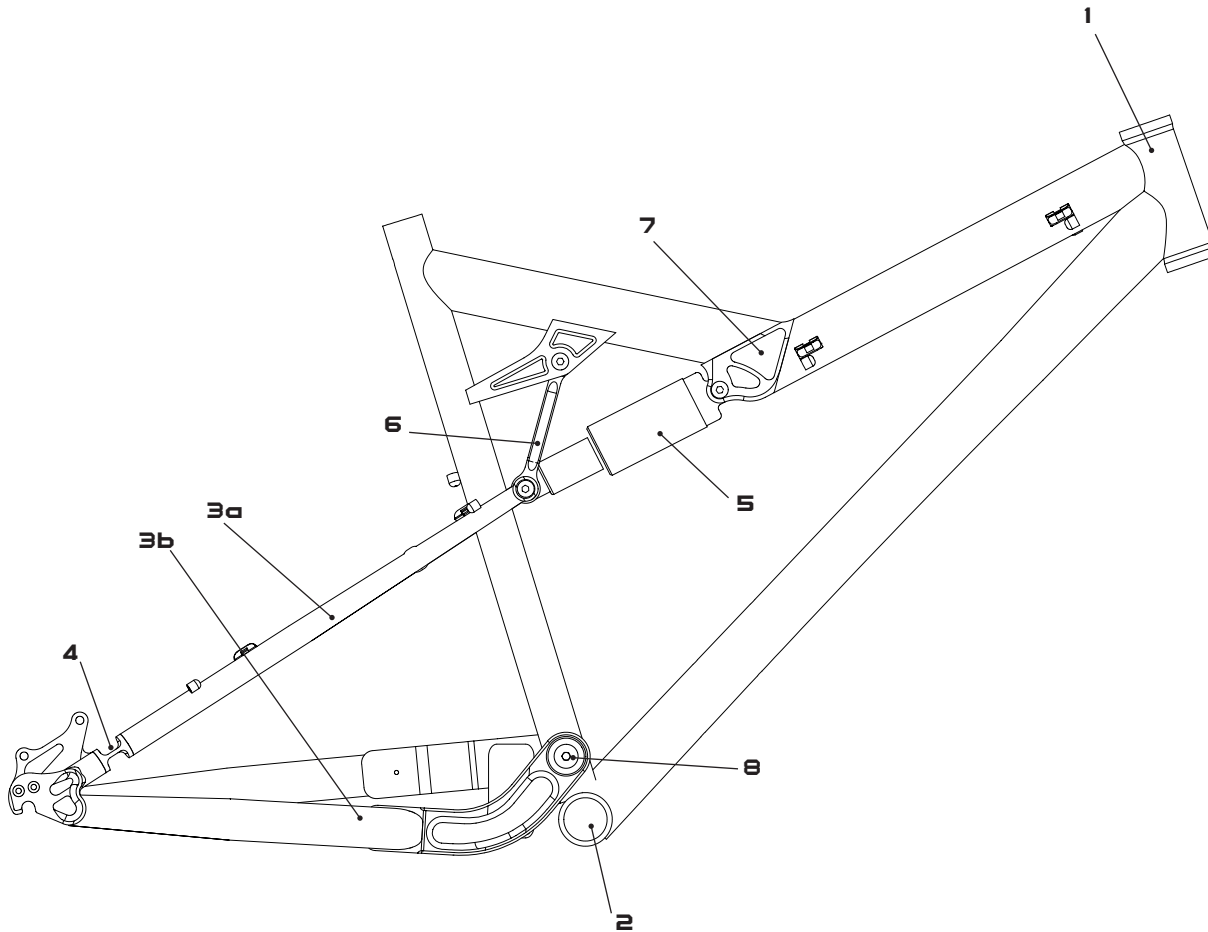

- PURE TUBING**
Yeti Pure tubing is custom butted and tapered to make a lightweight and strong frame without the use of gussets. Unique shape provides added strength at the head tube junctions.
- BOTTOM BRACKET**
73mm shell, for use with a 113mm spindle
- SEATSTAY (A) + CHAINSTAY (B)**
Carbon chainstay shaves 1/4 of a pound off the frame weight and maintains the lateral rigidity.
- FLEX PIVOTS**
Carbon Flex pivot allowed us to shave weight and increase performance. I-beam construction has great lateral stiffness, yet smooth suspension performance
- SHOCK**
6.5" eye-to-eye 1.5" stroke
- DOGBONE**
Dogbone controls suspension rate and also adds rear end stiffness work together
- KNUCKLE**
CNC machined knuckle increases stand-over height and positions the shock so the forces are directly in line with the top tube. This allows us to make the bike lighter, but still retain stand over clearance
- MAIN PIVOT**
Oversized sealed bearings on main pivot for low maintenance and stiction-free performance.

Geometry

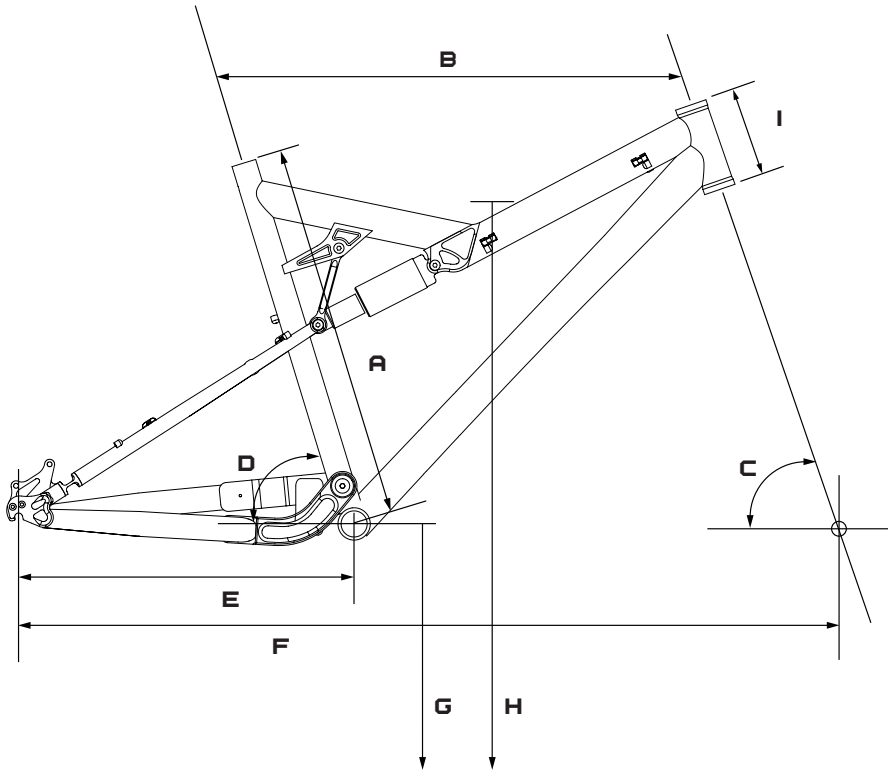

GEOMETRY AS-R_{SL}

100 MM FORK

	XS	S	M	L
A	16.75	18.0	19.0	21.3
B	21.0	22.4	23.4	24.4
C	74	73	73	73
D	71	71	71	71
E	16.9	16.9	16.9	16.9
F	40.3	41.6	42.6	43.6
G	12.75	12.75	12.75	12.75
H	27.5	28.0	28.0	28.0
I	4.0	4.0	4.5	5.25

*All measurements are in inches

Maintenance



MAINTENANCE? If you are having trouble with any of the maintenance tasks that need to be performed contact your local dealer or visit www.parktool.com and check out the repair help section. This section contains detailed instruction on many of the service items listed in the maintenance schedule.

MAINTENANCE YETI has outlined below the service and maintenance that can and should be performed by the owner and requires no special tools. Following these guidelines will help maintain the performance of your bicycle and prevent more serious problems from arising. This guide is by no means an absolute rule which to follow. Common sense should be practiced and if an issue surfaces before the maintenance schedule interval, visit an authorized dealer for inspection and or maintenance.

ACTION	WEEKLY	MONTHLY	3 MONTHS	ANNUALLY
Clean and Lube Chain	x			
Check tire pressure	x			
Clean bike of mud and debris (never spray water directly into frame or components)	x			
Check brake function	x			
Check shock pressure, if applicable	x			
Check for loose bolts and tighten if necessary		x		
Check headset and tighten/loosen if necessary		x		
Thoroughly clean pivot points with a rag (do not lubricate)		x		
Replace brake pads if necessary			x	
Check tires for wear			x	
Check spoke tension, and retention if necessary			x	
Check chain for worn, damaged, or loose links. Replace chain if necessary			x	
Complete tune-up performed by an authorized YETI dealer				x

TORQUE YETI has outlined a brief list of torque specifications for bolts and components that may need to be tightened while performing basic maintenance. This is by no means a comprehensive list, just a guide. If a bolt or component needs to be tightened that is not encompassed by this list, refer to the specific manufactures torque specification guide.

TORQUE SPECS

Pivot Bolts	125 - 150
Derailleur Hanger Bolts	30 - 45
Handlebar Binder Bolt	150 - 180
Stem Binder Bolt	175 - 260
Seatpost Binder Bolt	150 - 180
Saddle Clamp Bolts	175 - 250
Rear Derailleur	70 - 86
Front Derailleur Clamp	45 - 60
Chainring Bolts	88 - 132



Caution: The torque specifications listed should be used as a guide when performing maintenance. Technological advances have made bicycles and bicycle components more complex, and the pace of innovation is increasing. Because of these advances, YETI recommends that you refer to the torque specifications of the manufactures component you are adjusting. In order to help minimize the chances of an injury, do not perform any maintenance that you are not confident can be completed within your abilities.

Bike Setup



TOOLS NEEDED

- Shock Pump
- Tape Measure
- 4mm allen key

TIME

15-20 minutes

YETI TIPS

- Inspect your shock and make sure it is in good condition. If oil is leaking or there is visible damage. The shock should be returned to an Authorized Fox Racing Shox service center for repair.
- To remove the shock from the linkage will require the Yeti linkage tool. The linkage tool is necessary to properly disassemble and reassemble the linkage. Using a hammer to tap out the pin can cause damage to the linkage and shock. It can be purchase at our online www.yeticycles.com or through an authorized dealer.

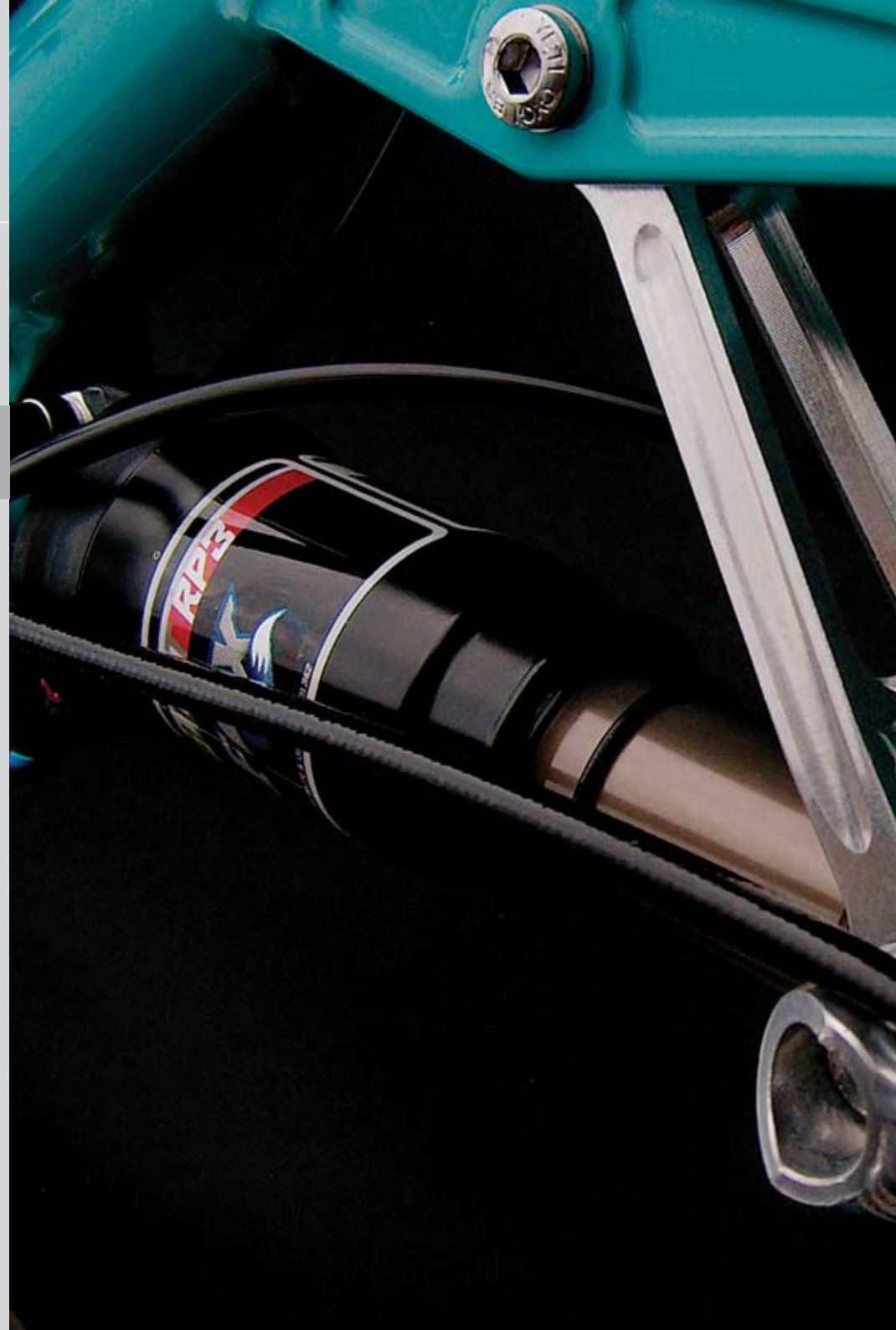

Setup-Fox RP3

Quick Start Guide

1 AIR PRESSURE The main air spring controls the sag of the shock. For the AS-Rsl to ride properly you must setup the shock with the correct amount of sag. For general riding use 20-25% of the shock stroke. To increase sag reduce the main spring air pressure. To reduce sag increase the main spring air pressure. Refer to the quick start guide to get your starting air pressure.



2 SAG Once you have set your baseline air pressure you need to measure the sag. To measure the sag slide the travel indicator (O-ring) up against the shock body. Next compress the shock by sitting on your bike and then get off. The distance between the shock body and the new position of the travel indicator (O-ring) is your sag. Refer to the guide below for the % of sag equivalents for the measurement recorded.



3 PRO-PEDAL The pro-pedal damping has three levels of adjustment and is controlled by the blue lever (formerly the lock-out lever). The three different levels of damping are light, medium, and heavy Pro-Pedal.

Yeti Recommends setting the pro-pedal in the middle of its adjustment range. If you feel like you the bike is too firm and is not absorbing the small bumps flick the lever to the light setting. If the bike feels sluggish and is bobbing under pedal force flick the lever to the heavy setting

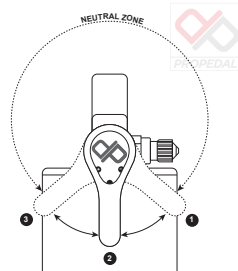

4 REBOUND The rebound adjustment has a 9 click range. As a general rule, adjustments that are too fast (counter-clockwise adjustment) will produce a springy ride with excessive kick up of the rear end causing bucking of the rider. Adjustments that are too slow (clockwise adjustment) will cause packing of the rear wheel that is identified by a sluggish ride feeling. 🇺🇸

Slower rebound - turn the knob clockwise
Faster rebound- turn the knob counter-clockwise



QUICK START GUIDE RP3 AS-Rsl

AIR SPRING SETTINGS

Rider Weight lbs	125	135	145	155	165	175	185	195	205	215
Air Pressure (psi)	105	115	125	135	140	150	155	165	175	185

SAG SETTINGS

Sag %	20	25	30
Measured (inches)	.300	.375	.400

*EXTERNAL ADJUSTMENTS

Rebound 4 Clicks

*All Clicks are clockwise rotation from all the way out or a full counter-clockwise position.



WHAT IS PRO-PEDAL? Pro-Pedal is compression tune that gives the right amount of low speed compression to filter out unwanted rider induced bob without sacrificing critical mid and high speed damping. No flushing through your travel, no wasted setup time, and no energy sucking suspension movement, just super efficient pedaling performance ready for hits of any size.

Line Setup

575 has full cable housing. Putting full cable housing helps prevent corrosion from the elements and thus keeps the shifting smoother for a longer period of time.



Caution: The failure to properly routing shifter housing can cause malfunction of the shift mechanism and unexpected shifting of gears.

1 REAR DERAILLEUR Fit a piece of housing from the rear shifter across the head tube into the first cable stop on non-drive side of the top tube.

Take another piece of housing and secure it in the second stop on the non-drive side of the top tube. Run the housing over the shock in to the stop on the seatstay. Make sure there is enough housing so it does not bind on the shock body.

The last piece of housing in run from the second stop on the seatstay into the derailleur.



2 FRONT DERAILLEUR Fit a piece of housing from the front shifter across the head tube into the first cable stop on drive side of the top tube.

Take another piece of housing and secure it in the second stop on the drive side of the top tube. Run the housing across the shock, through the space between the top of the dogbone and the under side of the top tube. Secure the end of this housing in the stop placed on the seatube. Create an arcing loop so the cable can run smoothly.



3 REAR BRAKE Run the brake line across the head tube to the first open cable stop on the non-drive side of the top tube

Run the line down along the shock body and into the first open cable stop on the seatstay. Continue down into the second stop on the seatstay and attach the line to the caliper. 🇧🇪

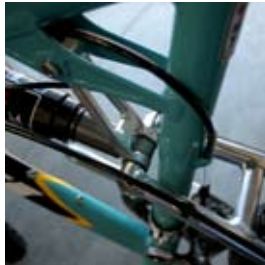

HOUSING END CAPS Yeti recommends using metal end caps. The metal caps do not allow the cable to pull through as do the plastic versions. Do not mix up the shift and brake housing because it will result in a loss in performance.



Assembly



TOOLS NEEDED

- Dead blow hammer
- Adjustable pliers
- Two - 5mm allen keys
- 6mm allen key
- 4mm allen key
- 4mm t-handle allen key
- 8mm allen key or 5/16 guide
- Linkage tool

TIME

30-45 minutes depending on condition of the bike

YETI TIPS

- Make sure your tools are in good condition. A worn allen key round the hex on a bolt not allowing for proper torque.
- Torque settings are listed throughout the instructions. It is also import to prep all bolt threads . The instruction denote wether to use a blue Loctite compound or grease.
- The linkage tool is necessary to properly disassemble and reassemble the linkage. Using a hammer to tap out the pin can cause damage to the linkage and shock.
- Not every too may be needed for the assembly/ disassembly of your bike. The list encompasses all the tools necessary to complete assembly/ disassembly on each bike



Warning: Service on Yeti bicycles requires special knowledge and tools. Yeti Cycles recommends that all service and repairs be performed by an authorized Yeti Dealer



Assembly



THREAD PREP Yeti recommends prepping all threads with Loctite or grease. The medium strength (blue) formula along with proper torque is ideal for keep the bolts snug.

1 LINKAGE ASSEMBLY To assemble the linkage you must first install and align the nylon washers between the Dogbone and shock. You want to make sure that the washers, shock eyelet, and Dogbone bearings are all concentric.



2 LINKAGE ASSEMBLY Slide a washer on the threaded bolt then slide this through the removal slug (1.5" long). Then slide on the shock pin. Slide the tool assembly through the Dogbone, shock connection point. On the opposing side slide on the catch sleeve and washer, then thread the nut on. Place the wrenches on the tool assembly and turn to re-set the shock pin.



3 LINKAGE ASSEMBLY When turning the tool make sure you press the shock pin into the correct position. The easiest way to gauge this is to use one of the nylon washers. The relief on the pin should be even with the washer.



4 FRAME ASSEMBLY Place the shock assembly onto the bike in the configuration shown to the right. Slide the 5/16 dickey or 8mm allen key through mounting position one to hold the shock assembly in place. Swing the Dogbone into mounting position two. Slide a 22mm female Yeti bolt and washer through the mounting hole. Tap the 22mm female Yeti bolt into position with the dead blow hammer.



5 FRAME ASSEMBLY Pull the dickey or 8mm allen key out slightly so you can get the 2mm female bolt started. Tap the 22mm female Yeti bolt into position with the dead blow hammer.



6 FRAME ASSEMBLY Thread a male Yeti bolt into the 22mm female bolt and tighten down with the 5mm allen keys. Repeat this step for second mounting position.
Note: The shoulder on the bolt should not be visible. The bolt should fit flush against the frame. Prep all bolt threads with blue loctite prior to assembly



7 FRAME ASSEMBLY Slide the rear triangle over the main pivot as shown. Notice the recess cut in the swingarm in front of the bearing. This recess should be lined up over the main pivot lip to ease the installation process. Make sure the bearings are lined up with the main pivot bore before tapping the lightly greased main pivot pin through the frame with the dead blow hammer.



8 FRAME ASSEMBLY Place the black washer over the main pivot pin as shown and thread the male button head on. Cinch the button head down with a 5mm allen key while holding the opposing side with the 6mm allen key.

Torque spec: 125-150 inch pounds.



Assembly Cont.

9 **FRAME ASSEMBLY** Place the plastic washers on both sides of the steel pin as shown. While holding the washers down slide the seatstays over the washers.



10 **FRAME ASSEMBLY** Slide the seatstays over the steel pivot pin. Then slide the 41.2mm female Yeti bolt and washer through the seatstays and shock assembly. Place a male Yeti bolt with a washer on the opposing side of the female bolt and thread into position. Cinch down both male Yeti bolts with the 5mm allen keys. The last step is to install the derailleur hanger and water bottle bolts.



Torque spec: 125-150 inch pounds 🇺🇸



Disassembly Tips

1 LINKAGE DISASSEMBLY Slide a washer on the threaded bolt then slide this through the removal slug (1.5" long). Slide the tool assembly through the Dogbone, shock connection point. On the opposing side slide on the catch sleeve and washer, then thread the nut on.



2 LINKAGE DISASSEMBLY Place the wrenches on the tool assembly and turn to press the pin out.



3 FRAME DISASSEMBLY To remove the main pivot pin, place a 5mm allen key on the button head bolt and a 6mm allen key on the pivot pin. Turn counter-clockwise until the button head is removed. Then take an 8mm allen key and tap out the main pivot pin.



4 FRAME DISASSEMBLY To remove the shock mounting bolt, place on 5mm allen key on both end of the bolt and turn counter-clockwise. Once the male Yeti bolt is removed, take a 6mm allen key and tap out the female end.



Note: this method works for all three mounting bolts on a Fox Racing shock. For a 5th element see the specified section on the following page.



CHANGES We strive to make the best bikes in the world, because of this dedication to be the best, we continually make changes to our bikes as needed. As the bikes are improved, assembly and setup instructions may be affected. Any amendments to the existing Owners Manual can be found on our website. www.yeticycles.com

5TH ELEMENT DISASSEMBLY NOTE The seatstay pivot has a unique disassembly technique. The system is made up of a steel female pin threaded on both side with a 4mm broach in the middle. Attached to this pin is two male Yeti bolts. Follow the instructions below to disassemble this pivot point. Also note there is a diagram of the steel pin below to aid in disassembly.

1 FRAME DISASSEMBLY First, take the two 5mm allen keys and loosen one of the male Yeti bolts. Remove the loosened Yeti bolt and set aside for reassembly.



2 FRAME DISASSEMBLY Slide a 4mm allen key inside of the threaded steel pin and feel for the 4mm hex in the middle of the pin. Take the 5mm allen key and turn counterclockwise against the 4mm allen key to break the assembly free. All the pieces to the seatstay pivot should now be loose and slide apart. 🇪🇸



STEEL PIN DIAGRAM

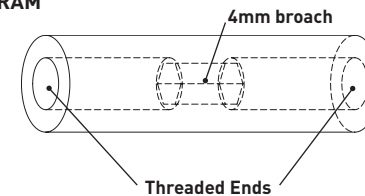

Exploded Views



REBUILD KITS The individual components of each Yeti bike are not sold separately. All yeti parts are sold in rebuild kits listed below. Each and every part can be obtained by purchasing one of the rebuild kits. Cross reference the part number you desire from the parts list to the rebuild list.

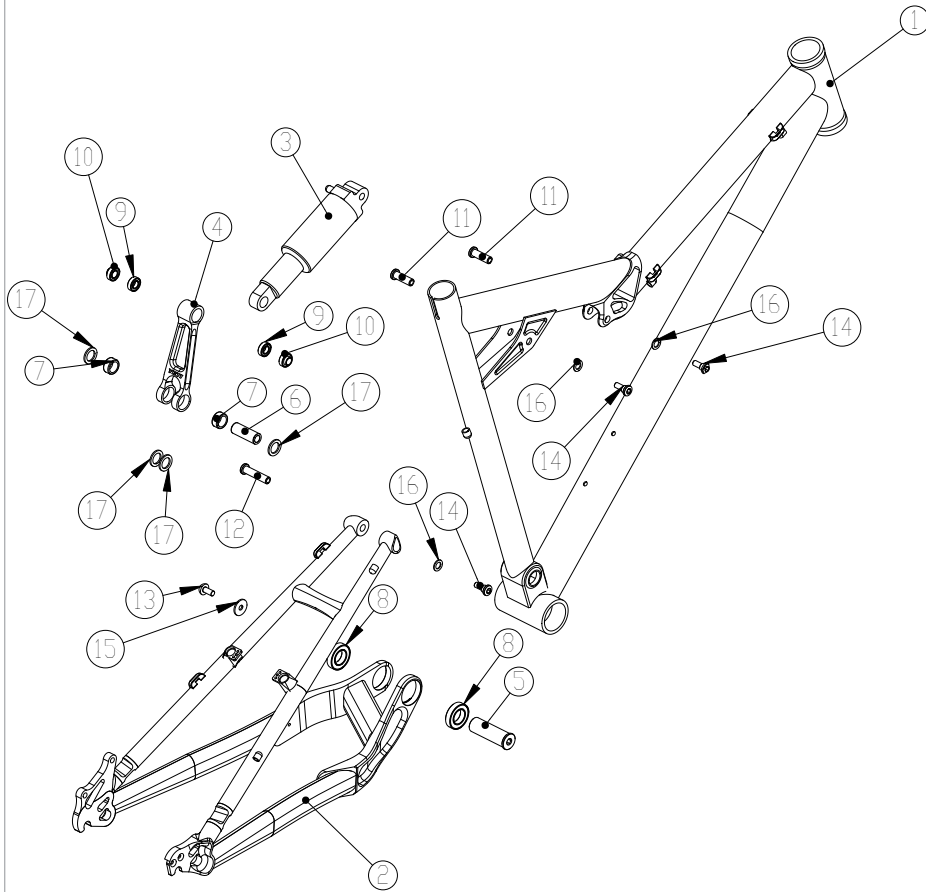

PARTS LIST W/FOX SHOCK

QTY.	PART #	DESCRIPTION
1	NA	Front Triangle
2	NA	Rear Triangle
3	NA	Shock
4	300040198	Dogbone - AS-Rsl
5	300030085	Main Pivot Pin
6	300030087	Steel Pin 1.38"
7	300020025	Needle Bearing
8	300020001	Main Pivot Bearing
9	300020027	688 2RS Bearing
10	300020026	688 2rs W/Ext Ring Bearing
11	300030077	Female Pivot Bolt 24.8mm
12	300030076	Female Pivot Bolt 35.5 mm
13	300030006	Button Head Bolt
14	300030078	Male Pivot Bolt 17mm
15	300030179	Washer Main Pivot 6061
16	300030069	Thin Washer
17	300030052	Nylon Washer

PARTS LIST W/5TH ELEMENT SHOCK

QTY.	PART #	DESCRIPTION
3	NA	5th Element Shock
4	300040198	Dogbone - AS-Rsl
6	300030090	Pin - Slider End 5th Shock
7	300020025	Needle Bearing
9	300020027	688 2RS Bearing
10	300020026	688 2rs W/Ext Ring Bearing
17	300030052	Nylon Washer
18	300030094	O-Ring 5th Shock
19	NA	Must Purchase From Progressive
20	NA	Must Purchase From Progressive
21	300030092	Hat-O-Ring 5th Shock

PROGRESSIVE 5TH ELEMENT SHOCK ASSEMBLY

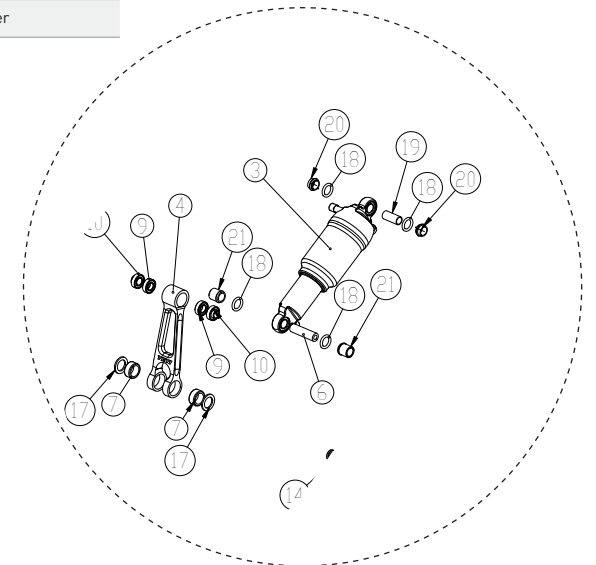

Parts List

PART NUMBER	DESCRIPTION	QTY.
500050066	AS-R 03-05 REAR TRI (BEARINGS NOT INCLUDED)	1
600000021	AS-R FRONTTRI	1
500060016	AS-R DOGBONE/BEARINGS '03-05	1
	300020027 AS-R 16MMX8MMX5MM BRG 688 2RS	2
	300020026 AS-R 16MMX8MMX5MM BRG W/EXT RING	2
	300020025 AS-R NEEDLE BRG .5 ID X .687 OD X .3125	2
300040198	AS-R 05' UL DOGBONE	1
200020070	AS-R '03-05 FOX MOUNTING HARDWARE	1
	300030087 PIN - STEEL SHOCK - 1.38	1
	300030078 BOLT-PIVOT-MALE YETI CR-MO,CP M6X17MM	1
	300030076 BOLT PIVOT FEMALE YETI CR-MO 35.5 MM	1
	300030069 WASHER SS 8.5MM ID 12.5MM OD .6MM THK	2
	300030052 WHASHER- NYLON .754" X .511" X .061"	4
200020080	AS-R '00-02 FOX MOUNTING HARDWARE	1
	300030086 PIN - STEEL SHOCK - 1.30 AS-R/KOKO/AS-X	1
	300030078 BOLT-PIVOT-MALE YETI CR-MO,CP M6X17MM	1
	300030076 BOLT PIVOT FEMALE YETI CR-MO 35.5 MM	1
	300030069 WASHER SS 8.5MM ID 12.5MM OD .6MM THK	2
	300030052 WHASHER- NYLON .754" X .511" X .061"	4
200020059	AS-R '03-05/575 PROGRESSIVE MOUNTING HARDWARE	1
	300030092 HAT-O-RING-PIN	2
	300030090 PIN	1
	300030094 O-RING	2
	300030052 WHASHER- NYLON .754" X .511" X .061"	2
	300030069 WASHER SS 8.5MM ID 12.5MM OD .6MM THK	2
	300030078 BOLT-PIVOT-MALE YETI CR-MO,CP M6X17MM	2
200020060	AS-R '00-02 PROGRESSIVE MOUNTING HARDWARE	1
	300030091 PIN -AS-R '02	1
	300030093 HAT-O-RING-PIN -AS-R '02	2
	300030094 O-RING	2
	300030052 WHASHER- NYLON .754" X .511" X .061"	2
	300030078 BOLT-PIVOT-MALE YETI CR-MO,CP M6X17MM	2
	300030069 WASHER SS 8.5MM ID 12.5MM OD .6MM THK	2
200020043	AS-R SL BEARING REBUILD KIT '03-05	1
	300030052 WASHER-BLK NYL.754X.511X.061 AS-R	4

PART NUMBER	DESCRIPTION	QTY.
	300020027 AS-R 16MMX8MMX5MM BRG 688 2RS	2
	300020026 AS-R 16MMX8MMX5MM BRG W/EXT RING	2
	300020025 AS-R NEEDLE BRG .5 ID X .687 OD X .3125	2
	300020001 BEARING 6903	2
200020040	AS-R BEARING REBUILD KIT '02	1
	300030082 BUSHING - MAIN PIVOT SHAFT INSERT KOKO/AS-R	2
	300030083 PIN - MAIN BEARING - KOKO/AS-R	1
	300030084 WASHER - KOKO/AS-R MAIN PIVOT	2
	300030006 BOLT-BUTTON HEAD M6X1X12 5MM	2
	300020024 BEARING R62RSMAX MAIN PIVOT KOKO/AS-R	2
	300030062 WASHER SS 6.5MM ID 12.5 OD .5MM THK	2
200020039	AS-R MAIN BUSHING REBUILD KIT '00-01	1
	300030072 WASHER SS 6MM ID 9MM OD 1MM THICK	1
	300060031 INSERT - BUSHING - NON-THREADED	1
	300060032 INSERT - BUSHING - THREADED	1
	300030054 BOLT - CAP 6X1X40	1
	300020011 BUSHING - TERCITE A - .750 ID	2
200020062	AS-R '03-05 MASTER REBUILD KIT (W/5TH MOUNTING HARDWARE)	1
	300020027 AS-R 16MMX8MMX5MM BRG 688 2RS	2
	300020026 AS-R 16MMX8MMX5MM BRG W/EXT RING	2
	300020025 AS-R NEEDLE BRG .5 ID X .687 OD X .3125	2
	300020001 BEARING 6903	2
	300030077 BOLT-PIVOT-FEMALE YETI CR-MO,CP 24.8MM	2
	300030078 BOLT-PIVOT-MALE YETI CR-MO,CP M6X17MM	4
	300030069 WASHER SS 8.5MM ID 12.5MM OD .6MM THK	6
	300030179 WHASHER MAIN PIVOT 6061	1
	300030085 MAIN PIVOT PIN 52.4MM LENGTH - AS-R	1
	300030006 BOLT-BUTTON HEAD M6X1X12	1
	300030092 HAT-O-RING-PIN	2
	300030090 PIN	1
	300030094 O-RING	2

Parts List

PART NUMBER	DESCRIPTION	QTY.
	300030052 WHASHER- NYLON .754" X .511" X .061"	2
200020061	AS-R '03-05 MASTER REBUILD KIT (W/FOX MOUNTING HARDWARE)	1
	300020027 AS-R 16MMX8MMX5MM BRG 688 2RS	2
	300020026 AS-R 16MMX8MMX5MM BRG W/EXT RING	2
	300020025 AS-R NEEDLE BRG .5 ID X .687 OD X .3125	2
	300020001 BEARING 6903	2
	300030076 BOLT PIVOT FEMALE YETI CR-MO 35.5 MM	1
	300030077 BOLT-PIVOT-FEMALE YETI CR-MO,CP 24.8MM	2
	300030078 BOLT-PIVOT-MALE YETI CR-MO,CP M6X17MM	3
	300030069 WASHER SS 8.5MM ID 12.5MM OD .6MM THK	6
	300030179 WHASHER MAIN PIVOT 6061	1
	300030085 MAIN PIVOT PIN 52.4MM LENGTH - AS-R	1
	300030006 BOLT-BUTTON HEAD M6X1X12	1
	300030087 PIN - STEEL SHOCK - 1.38	1
	300030052 WHASHER- NYLON .754" X .511" X .061"	4
200020074	AS-R '02 MASTER REBUILD KIT (BEARING MODEL)	1
	300030082 BUSHING - MAIN PIVOT SHAFT INSERT KOKO/AS-R	2
	300030083 PIN - MAIN BEARING - KOKO/AS-R	1
	300030084 WASHER - KOKO/AS-R MAIN PIVOT	2
	300030006 BOLT-BUTTON HEAD M6X1X12 5MM	2
	300020024 BEARING R62R5MAX MAIN PIVOT KOKO/AS-R	2
	300030086 PIN - STEEL SHOCK - 1.30 AS-R/KOKO	1
	300020017 GARLOCK DP BUSHING .5"X.25"	2
	300020016 BUSHING-IGUS-AS-R	6
	300020014 SLEEVE-INNER BUSHING-CLEVIS-AS-R	2
	300020013 SLEEVE-INNER BUSHING-DOGBONE-AS-R	1
	300030052 WASHER-BLK NYL.754X.511X.061 AS-R	6
	300030062 WASHER SS 6.5MM ID 12.5 OD .5MM THK	4
	300030069 WASHER SS 8.5MM ID 12.5MM OD .6MM THK	10
	300030076 BOLT-PIVOT-FEMALE YETI CR-MO,CP 35.5MM	1
	300030078 BOLT-PIVOT-MALE YETI CR-MO,CP M6X17MM	3
	300030077 BOLT-PIVOT-FEMALE YETI CR-MO,CP 24.8MM	2
	300030005 BOLT-PIVOT-7.95X20MM	2

PART NUMBER	DESCRIPTION	QTY.
	300030071 BOLT-BUTTON HD M6X1X17 5MM HEX	2
200020075	AS-R '00-01 MASTER REBUILD KIT (BUSHING MODEL)	1
	300030072 WASHER SS 6MM ID 9MM OD 1MM THICK	1
	300060031 INSERT - BUSHING - NON-THREADED	1
	300060030 INSERT - BUSHING - THREADED	1
	300030054 BOLT - CAP 6X1X40	1
	300020011 BUSHING - TERCITE A - .750 ID	2
	300030086 PIN - STEEL SHOCK - 1.30 AS-R/KOKO	1
	300020017 GARLOCK DP BUSHING .5"X.25"	2
	300020016 BUSHING-IGUS-AS-R	6
	300020014 SLEEVE-INNER BUSHING-CLEVIS-AS-R	2
	300020013 SLEEVE-INNER BUSHING-DOGBONE-AS-R	1
	300030052 WASHER-BLK NYL.754X.511X.061 AS-R	6
	300030062 WASHER SS 6.5MM ID 12.5 OD .5MM THK	2
	300030069 WASHER SS 8.5MM ID 12.5MM OD .6MM THK	10
	300030076 BOLT-PIVOT-FEMALE YETI CR-MO,CP 35.5MM	1
	300030078 BOLT-PIVOT-MALE YETI CR-MO,CP M6X17MM	3
	300030077 BOLT-PIVOT-FEMALE YETI CR-MO,CP 24.8MM	2
	300030005 BOLT-PIVOT-7.95X20MM	2
	300030071 BOLT-BUTTON HD M6X1X17 5MM HEX	2

Warranty

YETI LIMITED (2) TWO YEAR FRAME WARRANTY (applies to 303, DH-9, AS-X, 4X, DJ)

Yeti Cycles will repair or replace, at its option, any frame it determines to be defective due to defective materials and/or workmanship. The (2) two year limited warranty is conditioned upon the bicycle being ridden under normal conditions and having been properly maintained. This warranty does not apply to the components attached to the frameset such as suspension components, wheels, drive train, brakes, seatpost, handlebar and stem. This warranty applies only to the original owner and is non-transferable. This warranty is void if the bicycle was not properly assembled by an authorized Yeti dealer.

YETI LIMITED (5) FIVE YEAR FRAME WARRANTY (applies to AS-R-sl, AS-R, 575, ARC, FR0, Kokopelli)

Yeti Cycles will repair or replace, at its option, any frame it determines to be defective due to defective materials and/or workmanship. The (5) five year limited warranty is conditioned upon the bicycle being ridden under normal conditions and having been properly maintained. This warranty does not apply to the components attached to the frameset such as suspension components, wheels, drive train, brakes, seatpost, handlebar and stem. This warranty applies only to the original owner and is non-transferable. This warranty is void if the bicycle was not properly assembled by an authorized Yeti dealer.

ADDITIONAL CONDITIONS

These limited warranties do not apply to normal wear and tear, nor to claimed defects, malfunctions or failures that result from abuse, neglect, improper assembly, improper maintenance, alteration, collision, crash or misuse. The original owner shall pay all labor charges connected with the repair or removal of all components. Under no circumstance does this limited warranty include the cost of travel or shipment to and from an authorized Yeti dealer. In order to exercise your rights under these limited warranties, the bicycle or frameset must be presented to an authorized Yeti dealer, together with proof of purchase.

- › The above warranties have been in effect since January 2000. All Yeti frames sold prior to that date had a limited (1) one year warranty on the frameset.
- › No Fault Replacement Policy
- › Yeti Cycles will make replacement parts available at a minimum charge to the original owner in the event of a crash or any other non-warranty situation. Yeti Cycles does this at its sole discretion and reserves the right to refuse this offer.
- › If you have a warranty concern, please contact your authorized Yeti dealer.

NO FAULT REPLACEMENT POLICY

Yeti Cycles will make replacement parts available at a minimum charge to the original owner in the event of a crash or any other non-warranty situation. Yeti Cycles does this at its sole discretion and reserves the right to refuse this offer. If you have a warranty concern, please contact your authorized Yeti dealer.

PRODUCT LIFE CYCLE

Every YETI frameset has a useful product life cycle. The length of that useful product life cycle will vary depending on the construction and the materials of the frameset, maintenance and care the frameset receives, and the amount and type of use the frameset is subjected to over its life. YETI recommends that an authorized YETI dealer should inspect the frame for stress annually. Frame stress could cause potential failure and the signs are usually apparent in the form of cracks, fracture lines, deformation, dents, and any other visual indicators of abnormality. These safety check for frame stress are important to prevent accidents, injury to the cyclist, and product failure of a YETI frameset.

DISCLAIMER

YETI Cycles is not responsible for any damages to you or others arising from riding, transporting or other use of your bicycle. In the event that your frame breaks or malfunctions, YETI Cycles shall have no liability or obligation beyond the repair or replacement of your frame pursuant to the terms outlined in the warranty.

CONTACT INFO

YETI Cycles
600 Corporate Circle, Unit D
Golden, CO 80401
(p) 303-278-6909
(f) 303-278-6906
WWW.YETICYCLES.COM

BUSINESS HOURS

Monday-Friday
8AM-11:30AM, 1:00PM-5:30PM
(Mountain Time)