



YETI SB160 OWNER'S MANUAL

TABLE OF CONTENTS

OVERVIEW	03
FRAME FEATURES	04
SB160 GEOMETRY	05
FRAME STANDARDS	06
MAINTENANCE	07
FRAME ASSEMBLY	08
BEARING PRESS ASSEMBLY	11
SWITCH INFINITY BEARING ASSEMBLY	12
SEAT POST SET-UP	14
SWITCH INFINITY SERVICE	15
DROPPER POST INSERTION GUIDE	16
EXPLODED VIEW	17
REBUILD KITS	19
FREQUENTLY ASKED QUESTIONS	21
LIFETIME WARRANTY	23
CONTACT INFORMATION	23

CONGRATULATIONS ON YOUR PURCHASE OF A NEW YETI.

We are confident your new bicycle will exceed your expectations for value, performance, and ride quality. Each frameset and component has been custom specified and designed to enhance your riding experience. Whether you are a beginner cyclist, or a seasoned pro, your Yeti bicycle will provide endless hours of two-wheeled fun.

This model specific manual is designed to be used in conjunction with the general Yeti Owner's Manual and the manuals supplied by the suspension manufacturers. If you did not receive the Yeti Owner's Manual or the manual provided by the suspension manufacturer, download the materials off the Internet, or contact your local dealer. Bicycling can be a hazardous activity even under the best of circumstances. Proper maintenance of your bicycle is your responsibility and when done properly helps reduce the risk of injury and damage to your bicycle. **The SB160 is made specifically for off-road use only.**

This manual outlines basic setup and maintenance recommendations of your new Yeti. It is impossible to anticipate every situation or condition that may occur during the assembly, setup, and maintenance of your bicycle, Yeti recommends that all service and repairs be performed by your local authorized Yeti Dealer.

This manual contains many "Warnings" and "Cautions" concerning the consequences of failure to maintain or inspect your bicycle. The word "Warning" indicates a potentially hazardous situation in which, if not avoided, could result in serious injury or death. The word "Caution" indicates a potentially hazardous situation in which, if not avoided may result in minor injuries or damage to your bicycle or a component of your bicycle. Be sure to read and understand all of the Warnings and Cautions listed in the manual.



WARNING: Make sure you review and understand the warnings, instructions, and content of this manual and accompanying manuals for your bicycle.

WARNING: Technological advances have made bicycles and bicycle components more complex and the pace of innovation is increasing. It is impossible for this manual or the accompanying manuals to provide all the information required to properly repair and/or maintain your bicycle. In order to help minimize the chances of an injury, it is critical for you to have work performed by an authorized Yeti retailer.

THE LOWDOWN ON THE SB160 AND ITS FEATURES.

FRAME FEATURES

1 SWITCH INFINITY TECHNOLOGY PATENTED SUSPENSION SYSTEM

The SB160 delivers 160mm of rear travel with our patented Switch Infinity technology. Efficient pedaling performance while still smooth and supportive when the going gets rough.

2 HIGH MODULUS CARBON FIBER MAIN FRAME AND SWING ARM

High modulus carbon is hand laid to create our Turq Series frames. That same stiffness and efficiency can also be found in our carbon series frame sets.

3 FLOATING COLLET AXLE SYSTEM ON PIVOTS INCREASES BEARING LIFE

Floating colleted pivot axles help create a perfectly aligned connection between the front and rear triangles of the frame. Allowing the enduro max sealed bearings to keep things moving freely at the pivots.

4 INTEGRATED ISCG-05 MOUNTS

3-bolt ISCG-05 chain guide mounts are there for you in case you need extra drivetrain security for rowdy sections.

5 RATTLE-FREE CABLE PORT ASSEMBLY SECURES CABLES AND HOSES TO PROVIDE A SILENT RIDE

The SB160 is designed with clamping cable ports to insure a quiet ride, reduced cable movement and clean aesthetic. The ports are configurable so you can choose cable or wireless components without leaving behind open housing ports.

6 INTERNALLY MOLDED CABLE TUBES FOR HASSLE-FREE ROUTING AND A QUIET BIKE

Gone are the days of fishing your cables through your downtube hoping they pop out the other side. The SB160's internally molded cable tubes allow you to put the cable in one port and have it come out right where you want it.

7 INTEGRATED 41MM / 52MM TAPERED HEAD TUBE

Using an integrated head tube design on the SB160 allows for a larger head tube with more area, which results in increased stiffness, and lower overall ride height without compromising any performance.

8 CUSTOM DOWN TUBE PROTECTOR AND RIBBED CHAIN GUARDS TO DECREASE CHAIN SLAP NOISE

Custom seatstay, chainstay and down tube guards keep the ride quiet while protecting the frame. The nylon down tube guard keeps your bike protected where you need it most so you can focus on charging down the trail.

9 INTEGRATED AXLE AND UNIVERSAL DERAILLEUR HANGER SYSTEM

Dedicated 12 x 148 boost dropouts with SRAM's universal derailleur hanger (UDH) provide strength, stiffness and easy hanger and wheel installation.

10 CUSTOM TUNED REAR SHOCK

We develop custom suspension tunes from the ground up here in Golden, CO to optimize suspension performance to perfectly compliment the SB160 suspension kinematics. For help setting up your suspension, please visit our Shock Setup Guide.

<https://shocksetup.yeticycles.com/support>

GEOMETRY SB160

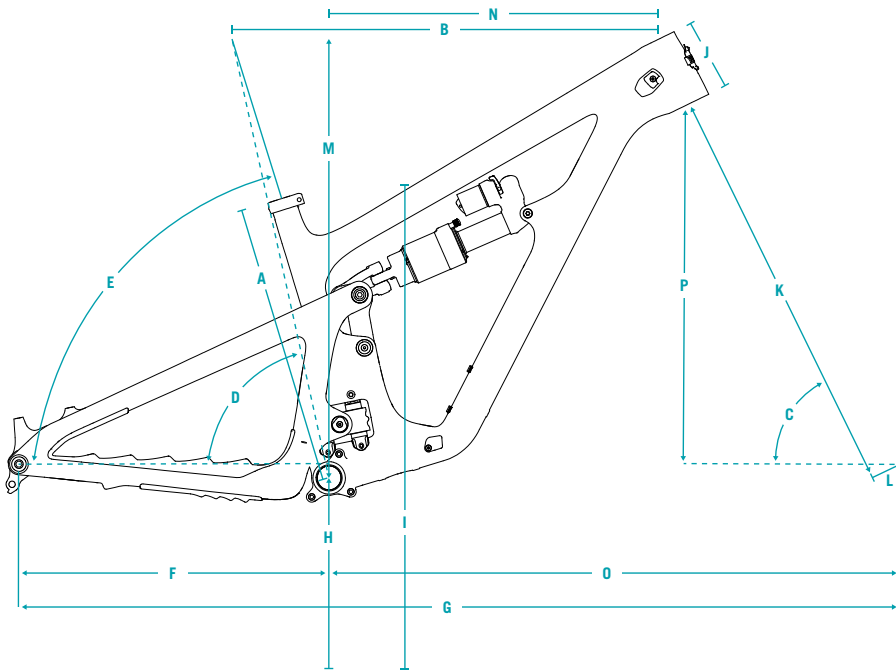

	170MM FORK	SM	MD	LG	XL	XXL
A	SEAT TUBE LENGTH	365	400	440	470	485
B	EFF. TOP TUBE LENGTH	571	602	624	651	670
C	HEAD TUBE ANGLE °	64	64	64	64	64
D	EFF. SEAT TUBE ANGLE °	77.5	77.5	77.5	77.5	77.5
E	ACTUAL SEAT TUBE ANGLE °	72.1	72.6	72.7	73.1	73.6
F	CHAINSTAY LENGTH	437	439	441	443	445
G	WHEELBASE	1211	1246	1270	1302	1329
H	ESTIMATED BB HEIGHT	353	353	353	353	353
I	STANDOVER	735	744	750	756	757
J	HEAD TUBE LENGTH	95	101	107	118	140
K	FORK (AXLE TO CROWN)	588	588	588	588	588
L	FORK (OFFSET)	44	44	44	44	44
M	STACK	615	620	625	635	655
N	REACH	435	465	485	510	525
O	FRONT CENTER	774	807	829	859	884
P	VERTICAL FORK TRAVEL	153	153	153	153	153

FIT

SMALL	5'1" (155 CM) – 5'7" (170 CM)
MEDIUM	5'5" (165 CM) – 5'11" (180 CM)
LARGE	5'10" (178 CM) – 6'3" (191 CM)
X-LARGE	6'1" (185 CM) – 6'7" (200 CM)
XX-LARGE	6'5" (195 CM) – 6'11" (210 CM)

FRAME STANDARDS

SB160 | OWNER'S MANUAL



TRAVEL	160MM
WHEEL SIZE	29"
FRAME SIZE	SM, MD, LG, XL, XXL
REAR SHOCK	230MM X 65MM
BOTTOM BRACKET	BSA 73MM
REAR WHEEL	148MM X 12MM (BOOST)
SEATPOST	31.6MM
CHAINLINE	55MM
HEADSET	INTEGRATED 41MM/52MM TAPERED
REAR BRAKE POST MOUNT	180MM
SHOCK HARDWARE	FRONT: M8X36MM REAR: CUSTOM INSERT
MIN/MAX CHAINRING	28T MIN/34T MAX
MIN MAX REAR ROTOR	180MM MIN/203MM MAX
AXLE SPEC	172MM M12X1

KEEP YOUR YETI FRESH AND CLEAN

MAINTENANCE OVERVIEW

Following these guidelines will help maintain the performance of your bicycle and prevent more serious problems from arising. It is important to remember that service intervals can vary depending on climate, trail conditions and riding frequency. Servicing your bike requires special knowledge and tools. If you are unsure about working on your own bicycle, contact your authorized Yeti Dealer for more information on general bicycle maintenance.

SCHEDULE	BEFORE EACH RIDE	MONTHLY	3 MONTHS	ANNUALLY
Clean and lube chain	●			
Check tire pressure	●			
Clean bike of mud and debris	●			
Check brake function	●			
Ensure all cable ends are covered with crimped cable end caps	●			
Check rims for deformations or cracks	●			
Check for loose bolts and tighten, if necessary		●		
Check headset and tighten/loosen, if necessary		●		
Check / replace brake pads			●	
Check tires for wear			●	
Check spoke tension, retention, if necessary			●	
Check chain for wear, replace if necessary			●	
Complete tune-up performed by an authorized Yeti Dealer				●

TORQUE

Yeti strongly recommends using a torque wrench when assembling your frame. Torque specifications for individual parts on the SB160 are listed below, as well as in the step by step assembly instructions later in the manual. For general bicycle maintenance please consult the torque specifications of the component you are adjusting.

KEY TORQUE SPECS

PART #	DESCRIPTION	TORQUE (Nm)
300030361	COLLET AXLE, 15MM X 58.5L, M15X1.5	25
300030364	SHOULDER SCREW, 15 X 27.35L, M15 THREAD, SS PIVOT	25
300030376	COLLET AXLE 15MM, 43.5L	25
300030378	COLLET WEDGE SUB-ASSUMBLTY 15MM, M4 THREADED WEDGE BOLT	14
300040486	COLLET WEDGE SUB-ASSEMBLY 10MM	8
300030057	SHCS, M6 X 1.0, 20L	12
300030296	COLLET AXLE M10X1.0, 30.5L X 10.5T	15
300030370	SCREW, MALE, M6X12.0MM	10
300030174	SCREW, FH, M4 X 0.7, 16L	2.5
300030177	SCREW, FH, M4 X 0.7, 25L	2.5
300030357	SHCS, LOW PROFILE, M5 X 0.8, 16L	5
300030173	SCREW, FH, M4 X 0.7, 10L	2.5
300060080	SRAM UNIVERSAL HANGER	25
100425018	REAR AXLE M12X1 X 172L BOLT-ON BLACK UDH	15
300060078	YETI SEAT CLAMP, BOLT ON, 31.6	5

FRAME ASSEMBLY

YETI TIPS

Make sure your tools are in good condition. A worn allen key can round the hex on a bolt not allowing for proper torque.

Torque settings are listed throughout the instructions and on page 7 of this manual. It is important to prep all bolt threads. The instructions denote whether to use a Loctite compound or grease and part locations, listed in parentheses, are shown in the exploded view on page 16. Please ensure all prep call outs are followed.

WARNING: Failure to follow prep instructions could lead to serious frame issues.

WARNING: Service on Yeti bicycles requires special knowledge and tools. Yeti Cycles recommends that all service and repairs be performed by an authorized Yeti Dealer.

TOOLS NEEDED

- Torque wrench(es), 5-25 Nm, CW and CCW Directions
- 2.5mm allen key
- 3mm allen key
- 4mm allen key
- 5mm allen key
- 6mm allen key
- 8mm allen key
- 10mm allen key
- 8mm guide pins
- 3" socket extender
- Blue Loctite (243)
- Grease

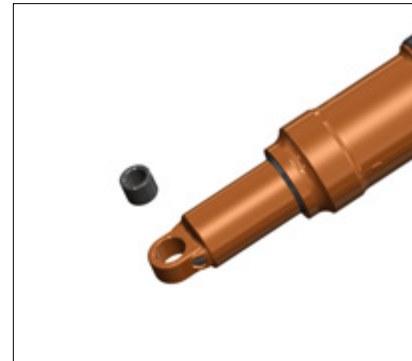

01

Press Shaft Eyelet Spacer (3.24) into rear shock eyelet.



02

Install 2X Low Profile H20 Bolts (3.27) and Washers (3.28) to front triangle.

Torque: **4 Nm** (or hand tight)



03

Install 2x Cable Port Clamps (3.29) to the front triangle with 2x M4 x 10L FHCS (3.33).

Install 1x Cable Port Clamp (3.29) to the rear triangle NDS Chainstay with 1x M4 x 10L FHCS (3.33).

Tighten until snug. Hardware can be torqued to **2-3 Nm** after housing installation.



04

Place a Head Tube Cable Port Cover (3.32) into each recess behind the head tube.

Place a Double Port Clamp (3.30) into the non-drive side cover and a Single Port Clamp (3.31) into the drive-side cover. Secure with M4 x 25L FHCS (3.26).

Tighten until snug. Hardware can be torqued to **2-3 Nm** after housing installation.



05

Install Lower DT Protector (3.37) to the front triangle using 3x Low Profile M5 Screws (3.27)

Torque: **5 Nm**



06

Assemble Switch Infinity Link (3.13) into frame using 4x SHCS (3.11) with Washers (3.12). Grease Zerks should face to the Non-Drive Side.

Torque in a cross pattern: **12 Nm**

Repeat torque to ensure all fasteners are fully tight.



07

Place 2x Race Extenders (3.5) onto the lower bearings in Link Assembly (3.16). Install into Front Triangle using Link Pivot Collet Axle (3.4) and plain Collet Nut (3.2).

Torque: **25 Nm**

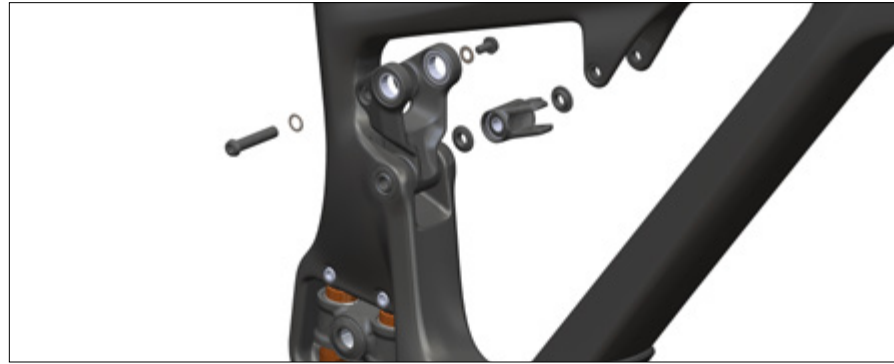

08

Assemble Upper (3.23) and Lower (3.22) Shock Extender to SB160 Link (3.16) by placing 2X Race Extender (3.15) in the extender cavities and sliding between the Link tabs. Threaded Extender (3.23) should be assembled on top. Secure with a Guide Pin and assemble Female 8x41mm Bolt (3.17) with Washer (3.21) through the assembly. Secure with Male M6 Bolt (3.19) and Washer (3.20).

Torque: **10 Nm**



09

Apply grease to main pivot cavities of Rear Triangle. Slide Rear Triangle Assembly onto main pivot and secure with Main Pivot Collet Axle (3.1) and Routing Collet Nut* (3.7), placing routing feature at the top.

Torque: **25 Nm**

Install a plain collet nut (3.2, flat top with no clamp feature) if kit uses a wireless drivetrain.



10

Place 2x Race Extenders (3.5) onto the upper bearings in Link Assembly (3.16). Rotate Rear Triangle and Link together, lining up SS Pivot bores.

Install 2x SS Pivot Screws (3.3) from the inside of the Link and partially into the Rear Triangle.

Place 2x plain Collet Nut (3.2) into the Rear Triangle.

Using a wrench from the outside of the Swingarm, begin tightening in the "left-hand" direction (this is still a standard thread, but installed from the inside), tightening the SS Pivot Screw and Collet Nut.

Torque: **25 Nm**



11

Install Large Collet Wedge Bolts (3.9) into 2x Collet Axles (3.1) and (3.4).

Torque: **14 Nm**



12

Install the Shock into the frame by securing front eyelet with a Guide Pin. Install small Collet Axle (3.14) through the lower Extender (3.22), through the Shock, and thread into Upper Extender (3.23).

Torque: **15 Nm**

Install Small Collet Wedge Bolt (3.10) into Axle.

Torque: **8 Nm**

**13**

Install Female 8x45mm Bolt (3.18) with Washer (3.21) through front Shock Eyelet and secure with M6 Male Bolt (3.19) and Washer (3.20).

Torque: **10 Nm**

**14**

Install Housing Clamp Cap (3.8) onto the drive-side main pivot axle with a M4 x 16L FHCS (3.25). Tighten until snug. Hardware can be torqued to **2-3 Nm** after housing installation.

**15**

Install a Housing Clamp Cap (3.8) and Clamp Base (3.6) onto the non-drive main pivot wedge bolt with a M4 x 25L FHCS (3.26).

Tighten until snug. Hardware can be torqued to **2-3 Nm** after housing installation.

**16**

Install Univesal Hanger (3.34) into frame. Do not use grease. Note that hanger cap bolt is reverse threaded.

Torque: **25 Nm**

BEARING PRESS ASSEMBLY

LINK BEARING PRESS

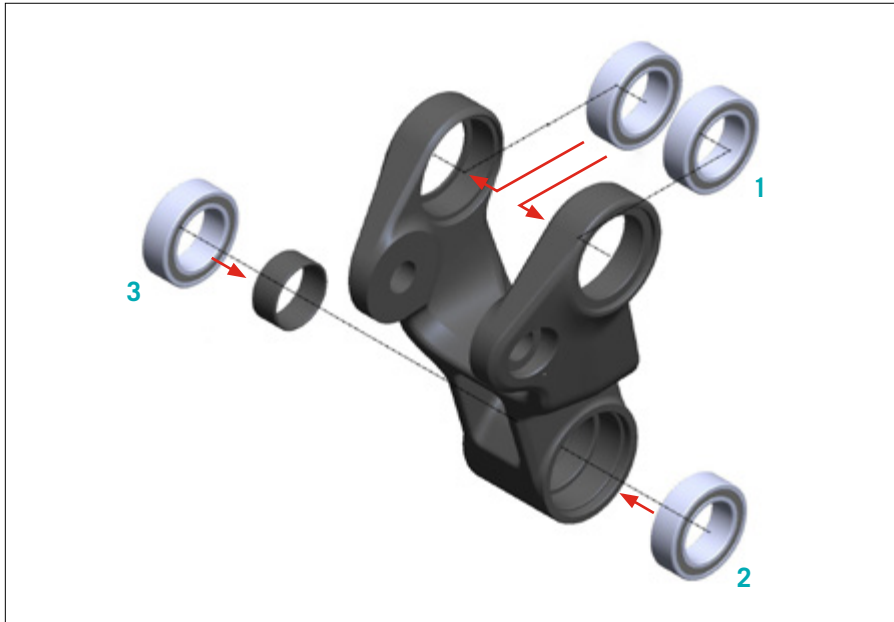

- 1 Press both upper bearings into the link from the inside of the link tabs using a 15x24mm arbor. Check that both bearings are fully seated.
- 2 Press the drive-side lower bearing into the link using a 15x24mm arbor, fully seating the bearing into the link.
- 3 Install the lower bearing spacer against the pressed lower bearing. Press the non-drive side bearing into the link until bearing bottoms against the spacer

EXTENDER BEARING PRESS

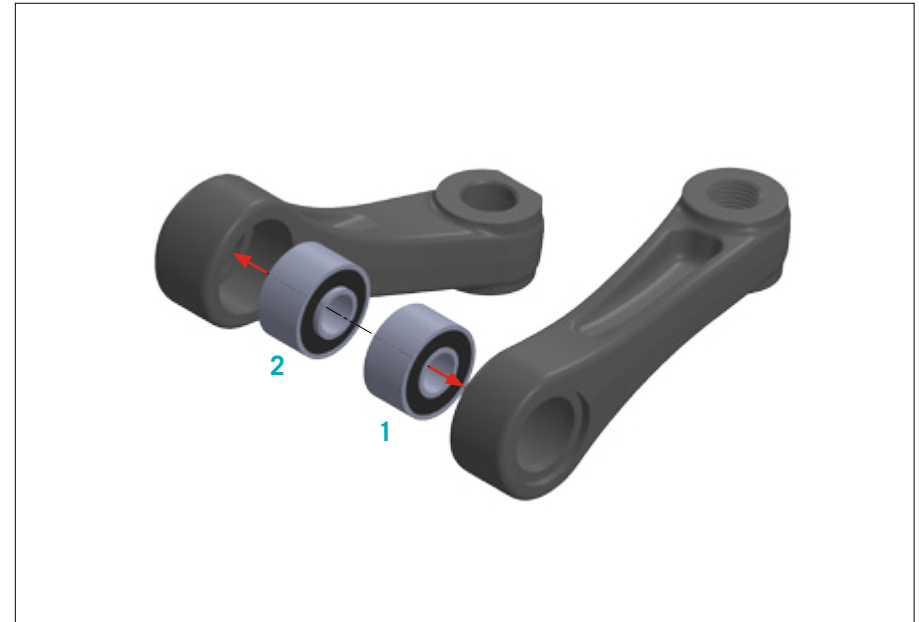

- 1 Press the bearing into the upper extender with the extended race facing out of the bore. Press into the extender until fully seated.
- 2 Press the bearing into the lower extender with the extended race facing out of the bore. Press into the extender until fully seated.

SWITCH INFINITY V2 BEARING ASSEMBLY

BEARING REMOVAL

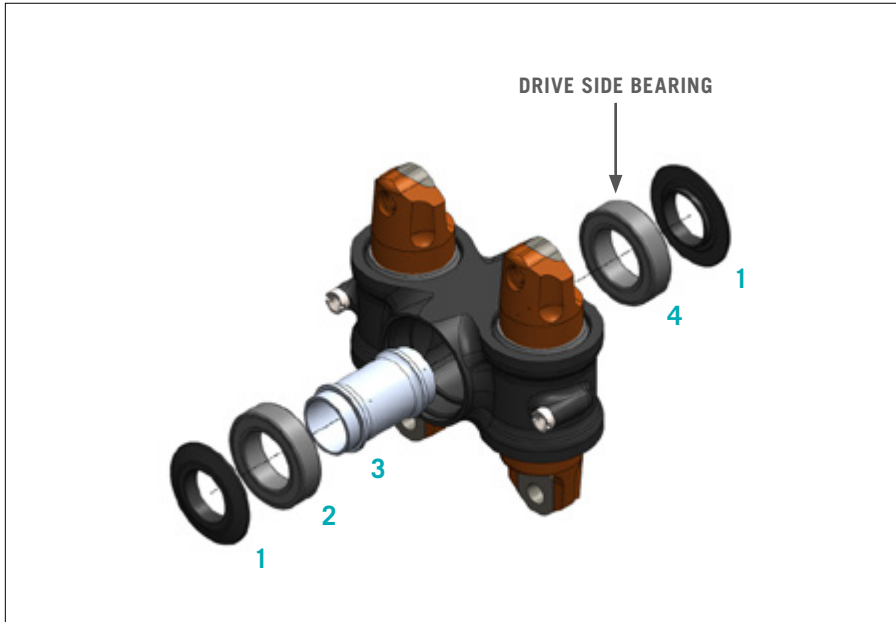

- 1 Remove dust caps on the outside of the bearings.
- 2 Remove non-drive side bearing.
- 3 Remove axle sleeve from drive side bearing.
- 4 Remove drive side bearing.

BEARING INSTALL

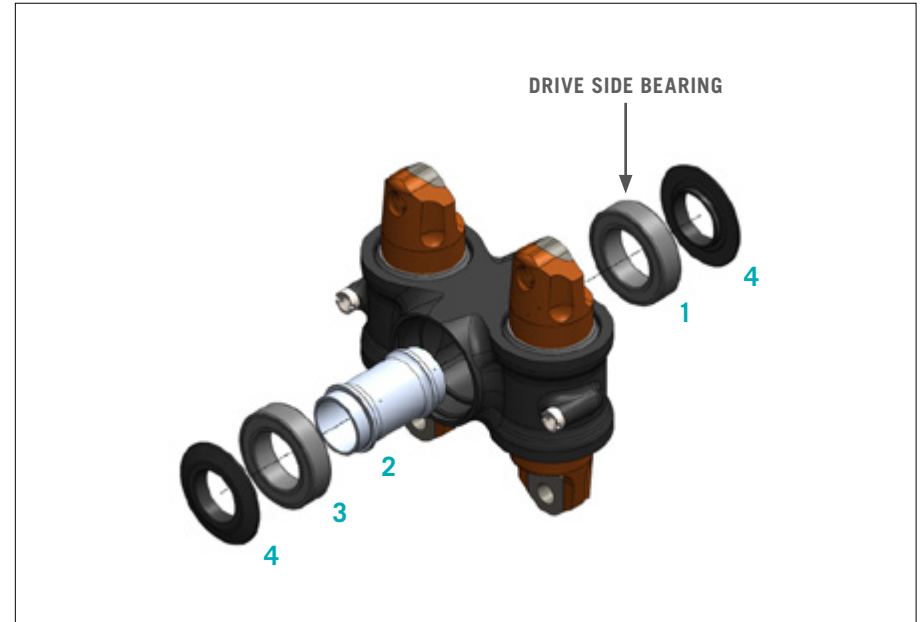

- 1 Press drive side bearing into Switch Infinity body.
- 2 Slide axle sleeve into drive side bearing.
- 3 Press non-drive side bearing onto sleeve.
- 4 Replace bearing caps.

SWITCH INFINITY V1 BEARING ASSEMBLY

BEARING REMOVAL

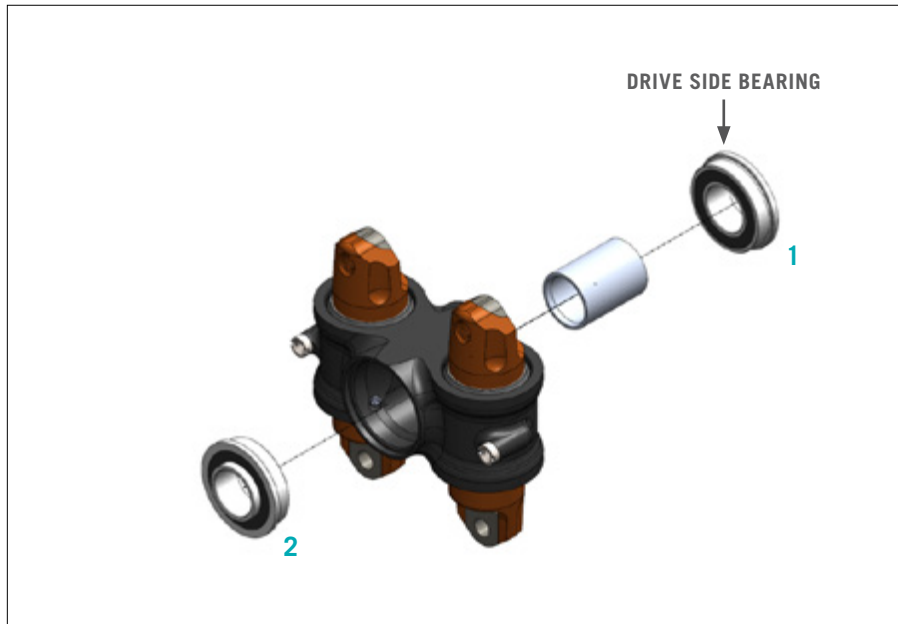

- 1 Remove drive side bearing and axle sleeve
- 2 Remove non-drive side bearing

BEARING INSTALL

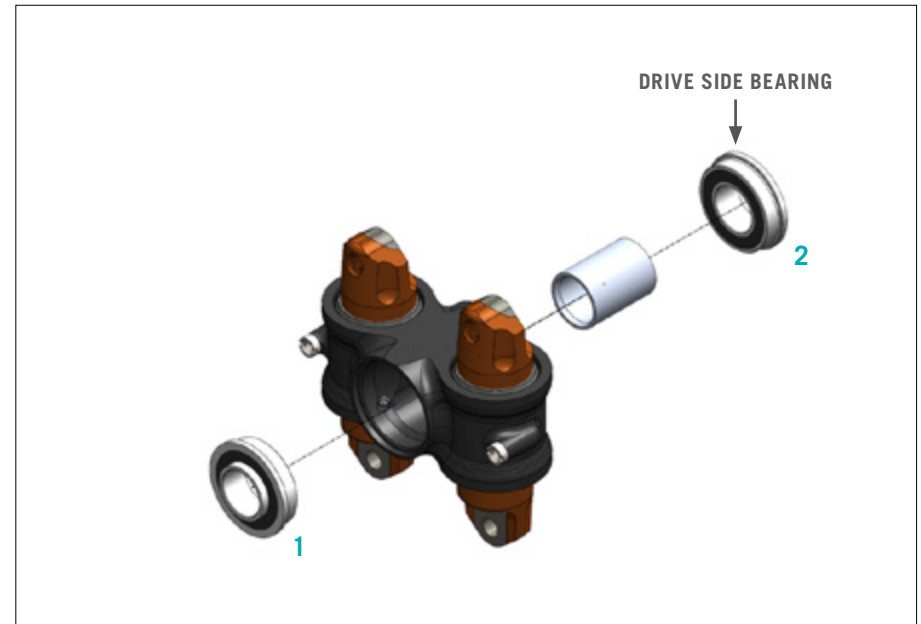

- 1 Press non-drive side bearing into switch infinity housing (ensure extended race is facing outward from switch infinity body).
- 2 Place axle sleeve in body and press drive side bearing into housing

SEAT POST SET-UP

STANDARD ROUTING SET-UP

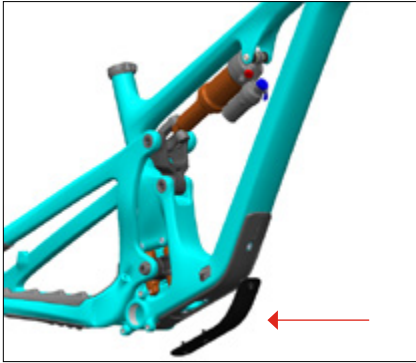

01

With a 3mm allen wrench, remove the outer plastic downtube protector.

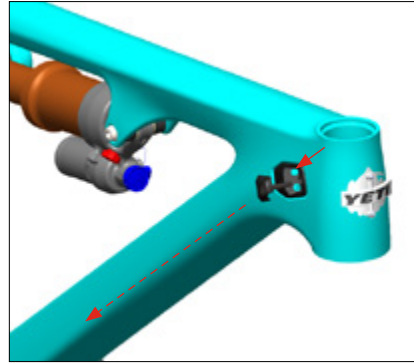

02

Install your seatpost housing into the drive-side head tube port, pushing until it exits near the downtube cable port access hole.

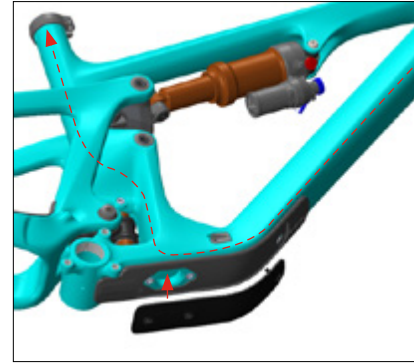

03

The hole under the downtube protector provides an access point to use your finger to help push the housing around the bend in the frame up into the seat tube.



04

While pushing the housing into the head tube port, continue guiding the cable up the seat tube through the access hole until the housing exits the seat tube.

SWITCH INFINITY SERVICE

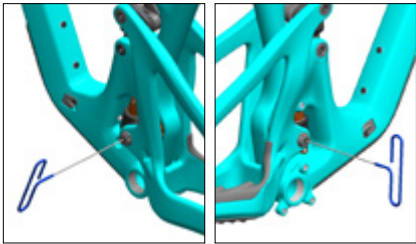

01

With a 2.5mm allen wrench, remove the two clamps securing the shifter and brake housing to the main pivot.

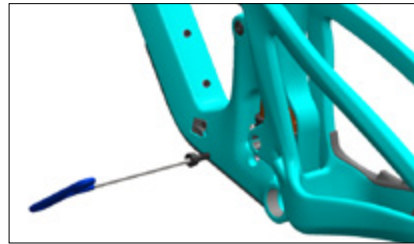

02

With a 5mm allen wrench, remove the main pivot Collet Wedge Bolt (3.9).

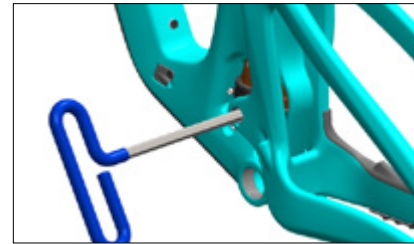

03

With a 10mm allen wrench, remove the Main Pivot Collet Axle (3.1).

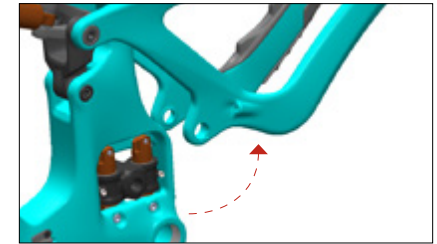

04

Rotate your swingarm upwards to expose the Switch Infinity Link and access both grease zerk. With a clean rag and mild detergent, clean any mud, dust, or debris off the Switch Infinity Link.



05

Remove the two dust caps from the Switch Infinity Link. Clean any debris or dust off the dust caps and bearing races in the Switch Infinity Link. Reinstall dust caps when finished.

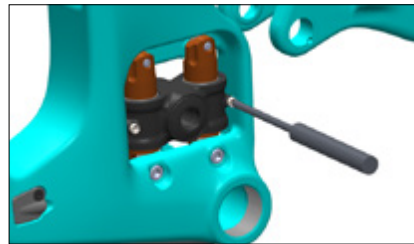

06

Using a needle-type grease gun, push new grease into the two Switch Infinity grease ports until you see fresh grease extruding from the shaft seals. Wipe off any excess grease that was pushed out of the seals.

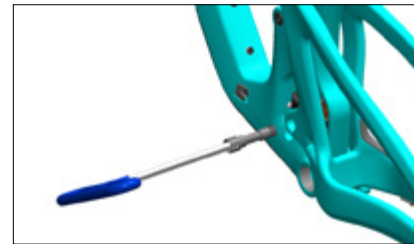

07

Apply assembly grease to the Main Pivot Collet Axle (3.1) shaft and head and apply anti-seize to the threads. Lower the swing arm and re-install your Main Pivot Collet Axle (3.1). Torque: **25 Nm**.

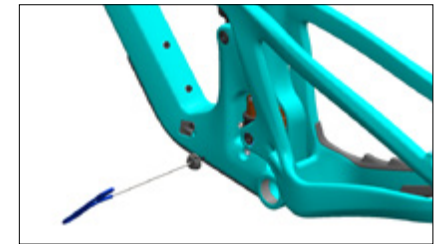

08

Apply assembly grease to the Main Pivot Collet Wedge head and threads. Install into the Main Pivot Collet Axle (3.1). Torque: **14 Nm**.

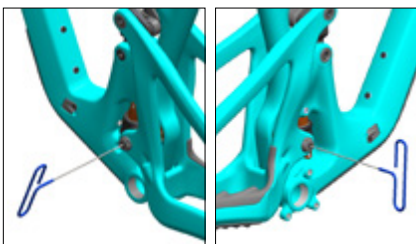

09

Re-install the housing clamps at the main pivot. Place a single clamp onto the shifter housing and secure with a M4 x 16L screw. Place a clamp and clamp base around the brake housing and secure with a M4 x 25L screw. Tighten until snug.

EXPLODED VIEW

- A Clamps
- B Collet Wedge Bolt (3.9)
- C Main Pivot Collet Axle (3.1)
- D Main Pivot Collet Wedge

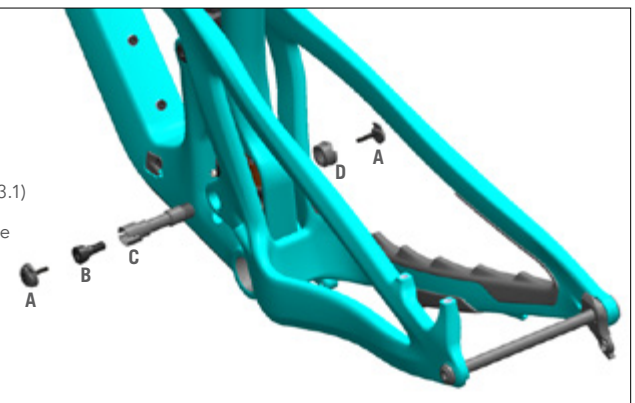

DROPPER POST INSERTION GUIDE

Droppers are an essential tool for the modern mountain bike but proper clearance checks are required before heading out for your first ride.

The key checks are as follows:

Ensure your dropper is short enough to fit into the seat tube without interfering with the frames structure but you are still able to achieve your desired BB-Saddle measurement. See the max insertion depth chart to confirm this distance for wired and wireless posts.

There are some scenarios where you can fit a longer dropper in your frame but when you drop your dropper the saddle or battery for AXS posts could interfere with your tire during a suspension compression. See the Min BB-Saddle at full drop to confirm this distance.

Always perform a final check to ensure your post is installed to at least the minimum insertion line. Also, compress the dropper and suspension, let the air out of your shock, to ensure there is no tire interference to the saddle or AXS battery at full bottom out.

We strive to spec out dropper lengths to provide the maximum drop for the highest percentage of our riders. There is a wide range of saddle heights for every frame size. There is a possibility saddle height could fall outside of this range. A small percentage of customers might find they require a shorter or longer post given their saddle height.

Please ensure you check the minimum dimensions in the below tables before going for your first ride. Failure to do so could result in tire to saddle rub or tire to battery contact for AXS posts.

Please confirm both of these measurements, they are both required to ensure proper dropper fitment.

If you have any questions, please contact Yeti or your local bike shop.

MINIMUM BB TO SADDLE CABLED DROPPER (MM)*		
FRAME SIZE	X-SMALL	498.5**
	SMALL	497.4**
	MEDIUM	496.5**
	LARGE	No min
	X-LARGE	No min
	XX-LARGE	No min

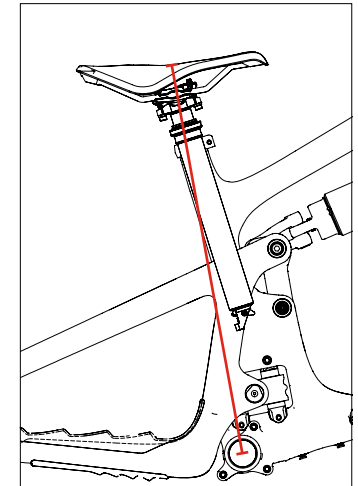

*These measurements are only for cabled droppers. Please make sure if you have a wireless post you confirm that there is not any interference of the tire hitting the battery when the post is fully dropped and the suspension is fully compressed.

**If you go lower then listed minimum you run the risk of tire to saddle interference.

MAX INSERTION WIRELESS DROPPER (MM)*		
FRAME SIZE	X-SMALL	232.2
	SMALL	242.8
	MEDIUM	277.4
	LARGE	316.8
	X-LARGE	331.0
	XX-LARGE	331.0

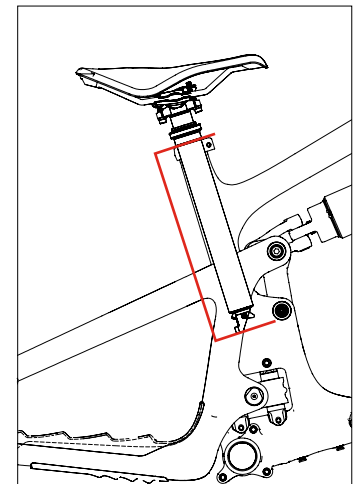

*Subtract 34mm for a cabled dropper to accommodate housing bend angle.

EXPLODED VIEW

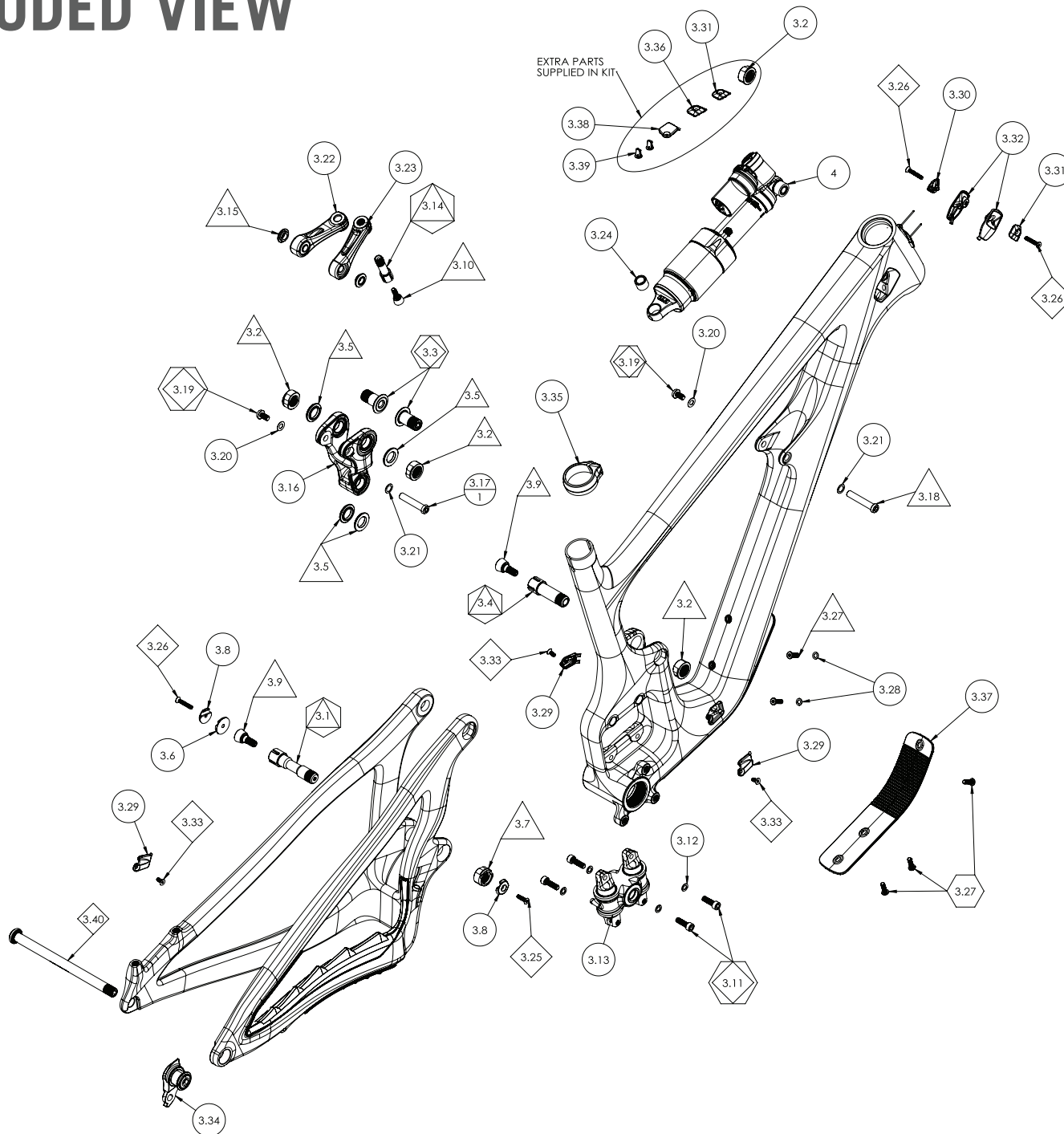

EXPLODED VIEW PARTS LIST

ITEM #	PART #	DESCRIPTION	TORQUE (NM)	QTY
1		SB160 FRONT TRIANGLE ASSEMBLY		1
1.1		SB160 FRONT TRIANGLE ASSEMBLY		1
2		SB160 SWINGARM ASSEMBLY		1
2.1		SB160 SWINGARM		1
3		SB160 SMALL PARTS ASSEMBLY		1
3.1	300030361	COLLET AXLE, 15MM X 58.5L, M15X1.5	25	1
3.2	300030362	COLLET NUT, M15, 9.5 THICK, ROUND CAP		4
3.3	300030364	SHOULDER SCREW, 15 X 27.35L, M15 THREAD, SS PIVOT	25	2
3.4	300030376	COLLET AXLE 15MM, 43.5L	25	1
3.5	300030365	RACE EXTENDER, 25 X 15.1 X 3.35		4
3.6	300030366	CLAMP BASE, 23MM X 3.5T, BRAKE HOUSING		1
3.7	300030367	COLLET NUT, M15 X 1.5, SHIFTER HOSE CLAMP		1
3.8	300030368	CLAMP CAP, HOUSING		2
3.9	300030378	COLLET WEDGE SUB-ASSEMBLY 15MM, M4 THREADED WEDGE BOLT	14	2
3.10	300040486	COLLET WEDGE SUB-ASSEMBLY 10MM	8	1
3.11	300030057	SHCS, M6 X 1.0, 20L	12	4
3.12	300030214	WASHER 6.3 X10.0 X 1.0 MM		4
3.13	200020422	ASSY, SWITCH INFINITY, MECHANISM, FACTORY SERIES		1
3.14	300030296	COLLET AXLE M10X1.0, 30.5L X 10.5T	15	1
3.15	300030375	SHOCK EXTENDER BEARING EXTENSION		2
3.16	200020409	SB160 LINK ASSEMBLY		1
3.16.1	300040540	SB160 LINK		1
3.16.2	HNA00000BA0000000000	BEARING, 3802-2RS, 15 X 24 X 7		4
3.16.3	300030369	SPACER, 15.2 X 17 X 7.3L		1
3.17	300030372	BOLT, FEMALE, 8 X 41.0, M6 THREAD		1
3.18	300030371	BOLT, FEMALE, 8 X 45.0, M6 THREAD		1
3.19	300030370	SCREW, MALE, M6X12.0MM	10	2

3.20	300030062	WASHER 6.5 X 12.5 X 0.5 MM		2
3.21	300030069	WASHER 8.5 X 12.5 X 0.5 MM		2
3.22	200020323	ASSY, SHOCK EXTENDER_60MM, BOTTOM		1
3.22.1	300040503	SHOCK EXTENDER BOTTOM [60MM]		1
3.22.2	300020032	BEARING, 398 MAX DBL, 8 X 19 X 10/11		1
3.23	200020322	ASSY, SHOCK EXTENDER_60MM, TOP		1
3.23.1	300040502	SHOCK EXTENDER TOP [60MM]		1
3.23.2	300020032	BEARING, 398 MAX DBL, 8 X 19 X 10/11		1
3.24	300030374	SHOCK EYELET SPACER		1
3.25	300030174	SCREW, FH, M4 X 0.7, 16L	2.5	1
3.26	300030177	SCREW, FH, M4 X 0.7, 25L	2.5	3
3.27	300030357	SHCS, LOW PROFILE, M5 X 0.8, 16L	5	5
3.28	300030358	WASHER 5.2 X 8.8 X 1.0 MM, STAINLESS ED BLACK		2
3.29	300040518	COVER-CABLE PORT, SINGLE, RIGHT EXIT		3
3.30	300040522	CLAMP, HT PORT DOUBLE, PA6		1
3.31	300040521	CLAMP, HT PORT SINGLE, PA6		2
3.32	300040524	CABLE PORT COVER, HEAD TUBE, 2 PIECE		2
3.33	300030173	SCREW, FH, M4 X 0.7, 10L	2.5	3
3.34	300060080	SRAM UNIVERSAL HANGER	25	1
3.35	300060078	ASSY, YETI SEAT CLAMP, BOLT ON, 31.6		1
3.36	300040523	COVER, HT PORT, BLIND, PA6		1
3.37	200020418	DT GUARD, MY23 OUTER, PA/ABS		1
3.38	300040542	COVER-CABLE PORT, BLANK, RIGHT EXIT		1
3.39	300040510	FRAME PLUG, CABLE PORT		2
3.40	100425018	REAR AXLE M12X1 X 172L BOLT-ON BLACK UDH	15	1
4		SB160 SHOCK SUB ASSEMBLY		1

REBUILD KITS

PART #	DESCRIPTION	QTY
200020435	LINK AND SHOCK EXTENDER BEARING REBUILD KIT	
HNA00000BA0 0000000000	BEARING, 3802-2RS, 15 X 24 X 7	4
300030369	SPACER, 15.2 X 17 X 7.3L	1
300020032	BEARING, 398 MAX DBL, 8 X 19 X 10/11	2
200020445	SWITCH INFINITY V2 BEARING REBUILD KIT	
300020060	BEARING MR17287 LLU MAX BO	2
300030383	SWITCH INFINITY V2 BEARING SPACER	1
200020436	CABLE PORT KIT	
300030177	SCREW, FH, M4 X 0.7, 25L	3
300040518	COVER-CABLE PORT, SINGLE, RIGHT EXIT	3
300040522	CLAMP, HT PORT DOUBLE, PA6	1
300040521	CLAMP, HT PORT SINGLE, PA6	2
300040524	CABLE PORT COVER, HEAD TUBE, 2 PIECE	2
300030173	SCREW, FH, M4 X 0.7, 10L	3
300040523	COVER, HT PORT, BLIND, PA6	1
300040542	COVER-CABLE PORT, BLANK, RIGHT EXIT	1
300040510	FRAME PLUG, CABLE PORT	2
300030366	CLAMP BASE, 23MM X 3.5T, BRAKE HOUSING	1
300030368	CLAMP CAP, HOUSING	2
300030367	COLLET NUT, M15 X 1.5, SHIFTER HOSE CLAMP	1
300030174	SCREW, FH, M4 X 0.7, 16L	1

200020437	NYLON DOWNTUBE PROTECTOR	
200020418	DT GUARD, MY23 OUTER, PA6	1
300030357	SHCS, LOW PROFILE, M5 X 0.8, 16L	3
200020438	SB160 PROTECTOR KIT	
200020406	CS/SS PROTECTOR, SB160	1
200020405	CS PROTECTOR, LOWER	1
200020419	DT GUARD, MY23 INNER, TPR	1
200020421	SHOCK EXTENDER KIT	
300040543	SHOCK EXTENDER, SB160, 25MM	1
300020032	BEARING, 398 MAX DBL, 8 X 19 X 10/11	2

200020441	HARDWARE REBUILD KIT	
300030361	COLLET AXLE, 15MM X 58.5L, M15X1.5	1
300030362	COLLET NUT, M15, 9.5 THICK, ROUND CAP	4
300030364	SHOULDER SCREW, 15 X 27.35L, M15 THREAD, SS PIVOT	2
300030376	COLLET AXLE 15MM, 43.5L	1
300030365	RACE EXTENDER, 25 X 15.1 X 3.35	4
300030366	CLAMP BASE, 23MM X 3.5T, BRAKE HOUSING	1
300030367	COLLET NUT, M15 X 1.5, SHIFTER HOSE CLAMP	1
300030368	CLAMP CAP, HOUSING	2
300030378	COLLET WEDGE SUB-ASSEMBLY 15MM, M4 THREADED WEDGE BOLT	2
300030057	SHCS, M6 X 1.0, 20L	4
300030214	WASHER 6.3 X10.0 X 1.0 MM	4
300030375	SHOCK EXTENDER BEARING EXTENSION	2
300030369	SPACER, 15.2 X 17 X 7.3L	1
300030377	SHOULDER SCREW, M10 X 23L, SHOCK EYELET	1
300030372	BOLT, FEMALE, 8 X 41.0, M6 THREAD	1
300030371	BOLT, FEMALE, 8 X 45.0, M6 THREAD	1
300030370	SCREW, MALE, M6X12.0MM	2
300030062	WASHER 6.5 X 12.5 X 0.5 MM	2
300030069	WASHER 8.5 X 12.5 X 0.5 MM	2
300030374	SHOCK EYELET SPACER	1
300030174	SCREW, FH, M4 X 0.7, 16L	1
300030177	SCREW, FH, M4 X 0.7, 25L	3
300030357	SHCS, LOW PROFILE, M5 X 0.8, 16L	5
300030358	WASHER 5.2 X 8.8 X 1.0 MM, STAINLESS ED BLACK	2
300040518	COVER-CABLE PORT, SINGLE, RIGHT EXIT	3
300040522	CLAMP, HT PORT DOUBLE, PA6	1
300040521	CLAMP, HT PORT SINGLE, PA6	2
300040524	CABLE PORT COVER, HEAD TUBE, 2 PIECE	2
300030173	SCREW, FH, M4 X 0.7, 10L	3
300040523	COVER, HT PORT, BLIND, PA6	1
300040542	COVER-CABLE PORT, BLANK, RIGHT EXIT	1
300040510	FRAME PLUG, CABLE PORT	2

200020443	AXS CONVERSION KIT	
300040510	FRAME PLUG, CABLE PORT	2
300040521	CLAMP, HT PORT SINGLE, PA6	1
300030177	SCREW, FH, M4 X 0.7, 25L	1
300030362	COLLET NUT, M15, 9.5 THICK, ROUND CAP	1
300030358	WASHER 5.2 X 8.8 X 1.0 MM, STAINLESS	1
300030173	SCREW, FH, M4 X 0.7, 10L	1

200020444	FOX LINEAR BEARING V2 KIT	
200020422	FOX LINEAR BEARING V2 FACTORY	1
300030057	SHCS, M6 X 1.0, 20L	4
300030214	WASHER 6.3 X10.0 X 1.0 MM	4

FRAME PROTECTOR SHEET

400100229	GLOSS	
400100230	MATTE	
200020354	FRAME PLUG CABLE PORT KIT	
400100202	SHUTTLE GUARD	
100425018	REAR AXLE M12X1 X 172L BOLT-ON BLACK UDH	
300060080	SRAM UNIVERSAL DERAILLEUR HANGER	
300030374	SHOCK EYELET SPACER	

FREQUENTLY ASKED QUESTIONS (1 OF 2)

WHAT IS THE DIFFERENCE BETWEEN THE TURQ AND CARBON SERIES SB160?

TURQ Series bikes are manufactured with the highest quality and best-performing carbon fiber available and offer the perfect balance of stiffness, durability, and compliance. The result is a bike that feels smooth, solid and aggressive. Carbon series bikes use a modified carbon fiber layup of our TURQ Series bikes. By using different materials and tweaking the fiber layup, we are able to make a more aggressively priced carbon high-performance mountain bike while maintaining the strength and stiffness of its higher end sibling. The carbon series SB160 weighs a bit more, about 225g for a frame.

WHAT IS SWITCH INFINITY TECHNOLOGY AND HOW DOES IT WORK?

Switch Infinity utilizes a patented translating pivot that automatically switches direction as the bike moves through its travel. This provides excellent anti-squat characteristics for superior pedaling performance and ideal suspension characteristics as it gets deeper into the travel. Inside are a pair of greased bushings that slide up and down on two Kashima coated rails – it's not an extra shock that needs to be filled with air. Just keep it greased and wiped clean per our maintenance recommendations below.

DOES THE SWITCH INFINITY SYSTEM REQUIRE MAINTENANCE?

The fully sealed Switch Infinity mechanism has external grease ports to lube the bushings and seals. Yeti and development partner Fox Racing Shox recommend a lubrication interval of 40 hrs of riding. It is important not to over lube the system and adhere to the recommended interval. It also doesn't hurt to wipe off any excess dust and dirt that may accumulate throughout the week. Any maintenance supplies you need can be found on our webstore or at your local dealer.

For detailed maintenance information, please visit <https://www.ridefox.com/fox17/help.php?m=bike&id=465>

CAN I REPLACE OR MODIFY ANY YETI FRAME PARTS ON MY SB160?

All replacement frame parts for your SB160 can be found through your local dealer or on our webstore. Only genuine Yeti parts should be used when replacing any parts on your frame. We know there are a lot of aftermarket products out there that seem legit but we do not have the ability to qualify and ensure all of these products are safe to use on our frames. If it is found that any frame part has been modified or replaced all warranties will be voided and all liability will be assumed by the customer.

CAN I CHANGE OR UPGRADE THE SPEC COMPONENTS ON MY SB160?

There are many options in aftermarket parts to upgrade or personalize your bike. Some parts are standardized, especially from the big brands like Fox, Shimano, SRAM etc. You should always confirm with a professional mechanic that your parts are the correct standard and correctly and securely mount to your bike without any interference or play. Pay special attention to all the bikes standards and check the fit before use

CAN I USE AN ANGLESET ON THE SB160?

The SB160 was designed with an integrated headset which has the headset cups molded into the frame so you can easily drop the bearings into the cups. There are some aftermarket angle-sets available for this style headset however the frame was not tested for the use of these and therefore should not be used. Yeti's warranty will be voided if it is found an angleset was installed on the frame and all liability will be assumed by the customer. See "What travel fork is the SB160 designed to use" for more information.

WHAT TRAVEL FORK IS THE SB160 DESIGNED TO USE?

The SB160 is designed to run a 170mm travel fork. We tested this frame to 20mm over the spec fork. So if you're feeling the need to beef up the fork you can run up to a 190mm fork no problem. Bottom line – max axle to crown measurement of 607mm. Increasing your fork travel will slacken the head angle and seat tube angle and raise the bottom bracket. Running a shorter fork is fine too if that suits you. Shortening the fork will steepen the head angle and seat tube angle and lower the bottom bracket. For more geometry information, check out the geometry section.

HOW BIG OF A TIRE CAN I FIT ON THE SB160?

The short answer is the SB160 can accept up to a 2.6" tire. There is great tire clearance on the SB160 but tire sizes vary widely by manufacturers, so it is hard to give a number that works for all brands.

CAN I FIT A WATER BOTTLE INSIDE THE FRONT TRIANGLE?

Yes, we designed the SB160 to accommodate a standard sized water bottle inside the front triangle of sizes L-XXL with a piggy-back shock. Size SM and MD frames will fit a standard 21oz water bottle with a piggy-back shock. We recommend using a side-entry cage for easiest access.

WHAT CRANKS AND BOTTOM BRACKET CAN I USE ON THE SB160?

The SB160 bottom-bracket standard is BSA 73mm and only wide "q" factor cranks are compatible. It is readily compatible with Shimano, SRAM, and RaceFace cranks, but a fit check is required for other brands.

WHAT REAR WHEEL AXLE FITS ON MY SB160?

The SB160 is designed to work exclusively with SRAM's Universal Derailleur Hanger at 12x148mm spacing. This axle has a thread pitch 12x1.0 and a length of 172mm. Note that this axle is only compatible with frames specifically designed with the Universal Derailleur Hanger.

WHAT TYPE OF HEADSET DOES THE SB160 USE?

The SB160 uses an Integrated 41mm/52mm tapered headset. This system allows for the headset bearings to be contained inside the head tube for an overall lower ride height, more simplified installation, and increased stiffness.

FREQUENTLY ASKED QUESTIONS (2 OF 2)

HOW BIG OF A ROTOR WILL FIT ON THE FRAME?

The SB160 has a direct mount rear brake tab and can run a 180mm rotor without the need for a brake adaptor. With the use of a brake adaptor the frame can accept up to a 203mm rotor.

CAN I RUN A STEALTH SEATPOST DROPPER ON THE SB160?

Yes. The SB160 has routing options for stealth only.

WHAT CHAINLINE WAS THE SB160 DESIGNED AROUND?

The SB160 was designed around a 55mm Boost chainline. Depending on the crank and chain ring configuration you can run other chainlines but you will have to do a clearance check first.

WHAT IS THE MAX SIZE SINGLE-CHAINRING THAT FITS ON THE SB160?

Without getting too technical, the max chainring size depends on the crank chainline and the chainring shape.

- Shimano / SRAM 55mm chainline Boost cranks: 34t round / 32t oval
- Minimum Chainring Size: 28t round / 30t oval

Confused? Ask your local dealer or call us 303.278.6909.

DOES THE SB160 HAVE ISCG MOUNTS?

Yes. The SB160 has integrated ISCG '05 mounts. It is designed to work best with low-profile modern guides; depending on the brand, some older models with larger upper guides may not fit. We always recommend performing a fit-check with a specific chainguide to confirm compatibility.

WHAT TYPE OF SHOCK DOES THE SB160 USE?

The SB160 uses a 230 x 65mm shock. Depending on the shock model, it can be locked out but we recommend running it fully open for the best compliance and traction.

WHAT TYPE OF SHOCK HARDWARE DOES THE SB160 USE?

The SB160 uses M8x36mm hardware on the air can side and a custom Yeti reducer on the shaft side. If you swap between shocks, the reducer can be found here, <https://www.yeticycles.com/gear/parts/shock-eyelet-spacer>

CAN I PUT A COIL SHOCK ON MY SB160?

Yes, the SB160 is designed to be compatible with both air and coil-sprung shocks.

WHAT PERCENTAGE SAG DO YOU RECOMMEND FOR THE SB160?

We would advise starting with 30% sag, or 19.5mm of shock stroke for optimal pedaling efficiency and terrain compliance. Be sure to set your sag at your normal riding weight, gear included. Feel free to venture slightly above or below 30% to suit your personal preference.

Visit our shock set up page to help set up your suspension, <https://shocksetup.yeticycles.com/calculator>

WHAT SIZE SEAT POST DOES THE SB160 USE?

The SB160 uses a 31.6mm seat post.

WHAT SIZE SEAT COLLAR DOES THE SB160 USE?

The SB160 uses a 36.4mm seat collar.

WHAT IS THE WARRANTY ON MY SB160?

The SB160 has a LIFETIME manufacturer's warranty.

WHAT IS THE LONGEST TRAVEL DROPPER POST I CAN RUN ON THE SB160?

This is mostly defined by your inseam. You can run any travel as long as you are above the minimum insert mark and you are not so low your tire rubs on your saddle or your dropper bottoms out in the frame. Your local Yeti dealer can help you sort this out. We run 150mm drop on SM frames, 175mm drop on MD frames and a 200mm drop on LG-XXL.

CAN I CONVERT THIS BIKE INTO A "MULLET" BIKE AND PUT A 27.5" WHEEL ON REAR OF THE SB160?

It is possible, but we would not suggest it as it would lower your BB too much and slacken your head tube angle and seat tube angle. But hey, if those changes suit your ride style then go for it.

WHAT HEADSET TOP CAP DOES THE SB160 USE?

The SB160 uses a 51mm top cap rather than the standard cap diameter. We use this larger cap because the SB160 is tested to Yeti's more rigorous DH test standards which require a larger headtube wall thickness.

LIFETIME WARRANTY

HERE'S EVERYTHING YOU NEED TO KNOW ABOUT OUR LIFETIME WARRANTY:

All 2019 (or newer) frames, including the Switch Infinity, are covered for life against damage due to manufacturing defects for the original purchaser. Paint and finish are covered for 1-year. We will repair or replace, at our discretion, any frame we deem defective. There are a few conditions: you must register it online at yeticycles.com and you must take it to an authorized Yeti Cycles dealer for processing. Warranty does not cover damage due to ordinary wear and tear, neglect or intentional destruction. From a slingshot or your truck.

If you happen to have a crash or non-warranty situation, we'll get you back on the trail with a reasonable replacement price. Same conditions as above.

Lifetime Warranty applies to all 2019 and newer frames (including the SB100). Model year 2018 and older frames will be covered under our previous warranty (5-year or 2-year based on time of purchase).

Simple as that. No fine print.

DISCLAIMER

Yeti Cycles is not responsible for any damages to you or others arising from riding, transporting or other use of your bicycle. In the event that your frame breaks or malfunctions, Yeti Cycles shall have no liability or obligation beyond the repair or replacement of your frame pursuant to the terms outlined in the warranty.

*If you have a warranty concern, please contact your authorized Yeti Cycles dealer.

YETI CYCLES

621 Corporate Circle, Unit
B Golden, CO 80401
(p) 303-278-6909
(f) 303-278-6906
yeticycles.com

BUSINESS HOURS

Monday-Friday
8AM-11:30AM (MST)
1:00PM-5:30PM (MST)