



OWNER'S MANUAL 2012 YETI 4X

YETI CYCLES
600 Corporate Circle, Unit D
Golden, CO 80401
888.576.9384

www.yeticycles.com



TABLE OF CONTENTS

BRAND OVERVIEW	06
FRAME FEATURES	08
GEOMETRY	10
MAINTENANCE SCHEDULE	12
<i>SETUP</i>	
OVERVIEW	14
SHOCK SETUP	15
QUICK START GUIDE	16
CABLE/LINE SETUP	18
<i>TECHNICAL</i>	
ASSEMBLY OVERVIEW	20
EXPLODED VIEWS	24
REBUILD KITS	26
<i>LEGAL</i>	
WARRANTY	28
CONTACT INFORMATION	29

CONGRATULATIONS ON YOUR PURCHASE OF A NEW YETI.

We are confident your new bicycle will exceed your expectations for value, performance, and ride quality. Each frameset and component has been custom specified and designed to enhance your riding experience. Whether you are a beginner cyclist, or a seasoned pro, your Yeti bicycle will provide endless hours of two-wheeled fun.

This model specific manual is designed to be used in conjunction with the general Yeti Owner's Manual and the manuals supplied by the suspension manufactures. If you did not receive the Yeti owner's manual or the manual provided by the suspension manufacturer download the materials off the Internet, or contact your local dealer.

Bicycling can be a hazardous activity even under the best of circumstances. Proper maintenance of your bicycle is your responsibility and when done properly helps reduce the risk of injury and damage to your bicycle.

Warning: Make sure you review and understand the warnings, instructions, and content of this manual and accompanying manuals for your bicycle.

Warning: Technological advances have made bicycles and bicycle components more complex and the pace of innovation is increasing. It is impossible for this manual or the accompanying manuals to provide all the information required to properly repair and/or maintain your bicycle. In order to help minimize the chances of an injury, it is critical for you to have work performed by an authorized Yeti retailer.

This manual outlines basic setup and maintenance recommendations of your new Yeti. Because it is impossible to anticipate every situation or condition that may occur during the assembly, setup, and maintenance of your bicycle, Yeti recommends that all service and repairs be performed by your local authorized Yeti Dealer.

This manual contains many "Warnings" and "Cautions" concerning the consequences of failure to maintain or inspect your bicycle. The word "Warning" indicates a potentially hazardous situation in which, if not avoided, could result in serious injury or death. The word "Caution" indicates a potentially hazardous situation in which, if not avoided may result in minor injuries or damage to your bicycle or a component of your bicycle. Be sure to read and understand all of the Warnings and Cautions listed in the manual.

YETI 4X PURPOSE BUILT FOR RACING AND ABUSE.

1. YETI PURE TUBING
2. REAR SHOCK BY FOX RACING SHOX
3. 73 MM BOTTOM BRACKET SHELL
4. REPLACEABLE DERAILLEUR HANGER
5. OVERSIZED SEAT STAYS AND CHAIN STAYS
6. ALUMINUM DOGBONE

1. Yeti pure tubing is custom butted and tapered 7005 aluminum. This makes the frame lightweight and strong without the use of gussets. The unique shape provides added strength at the head tube junctions.
2. The 4X uses a 1.5 inch stroke, 6.5 inch eye to eye shock, by Fox Racing Shox.
3. The 4X features a 73mm bottom bracket shell, for use with a 113mm spindle.
4. Saves your expensive components and allows for a quick replacement in case of damage.
5. The oversized box-stays are stiff and strong and translate rider torque onto the dirt.
6. The aluminum dogbone helps create the ideal shock rate and provides a solid connection between the front and rear of the bike. Enduro max sealed bearings keep the dogbone moving freely.

GEOMETRY

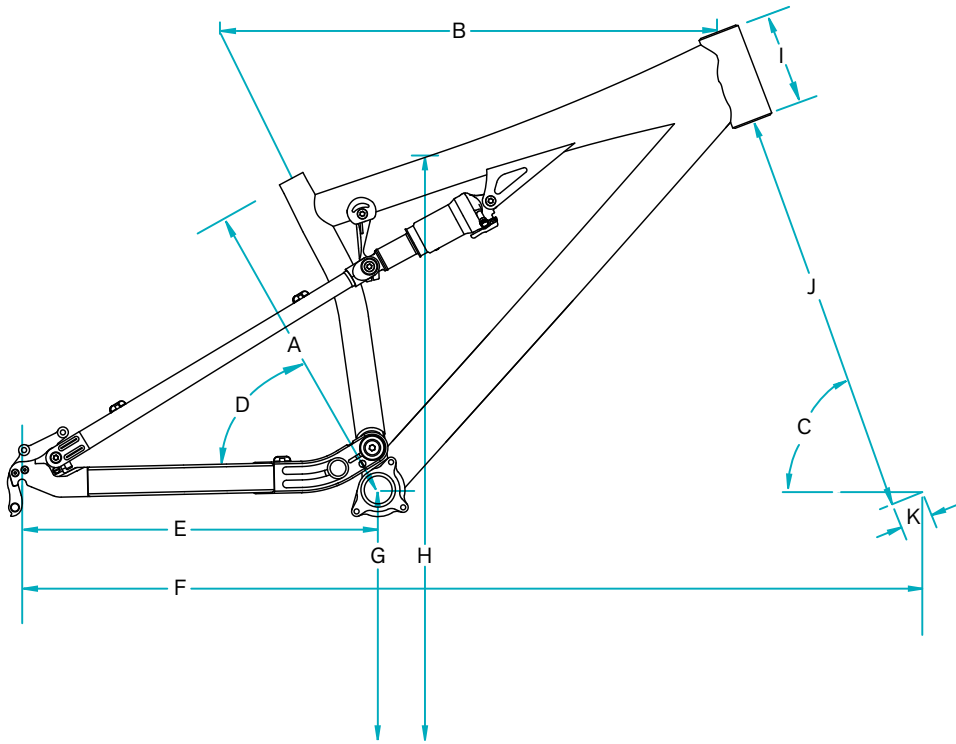

100 MM FORK

	S	L
A	16.5	18.0
B	23.1	24.1
C	67.0	67.0
D	72.0	72.0
E	17.1	17.1
F	44.2	45.2
G	13.4	13.4
H	27.0	28.1
I	4.9	4.9
J	20.5	20.5
K	1.5	1.5

**All measurements are in inches*

FIT

SHORT 5'0" (153 CM) - 5'7" (171 CM)

LONG 5'7" (171 CM) - 6'5" (196 CM)

KEEP YOUR NEW YETI FRESH AND CLEAN

OVERVIEW

Following these guidelines will help maintain the performance of your bicycle and prevent more serious problems from arising. It is important to remember that service intervals can vary depending on climate, trail conditions and riding frequency. If you are unsure about working on your own bicycle, contact your authorized Yeti Dealer or visit the repair help section at www.parktool.com for more information on general bicycle maintenance.

SCHEDULE

	WEEKLY	MONTHLY	3 MONTHS	ANNUALLY
CLEAN AND LUBE CHAIN	■			
CHECK TIRE PRESSURE	■			
CLEAN BIKE OF MUD AND DEBRIS	■			
CHECK BRAKE FUNCTION	■			
CHECK SHOCK PRESSURE, IF APPLICABLE	■			
CHECK FOR LOOSE BOLTS AND TIGHTEN, IF NECESSARY	■			
CHECK HEADSET AND TIGHTEN / LOOSEN, IF NECESSARY		■		
THOROUGHLY CLEAN PIVOT POINTS WITH A RAG (DO NOT LUBRICATE)		■		
REPLACE BRAKE PADS, IF NECESSARY			■	
CHECK TIRES FOR WEAR			■	
CHECK SPOKE TENSION AND RETENTION, IF NECESSARY			■	
CHECK CHAIN FOR WEAR AND REPLACE IF NECESSARY			■	
COMPLETE TUNE-UP PERFORMED BY AN AUTHORIZED YETI DEALER				■

TORQUE

Yeti strongly recommends using a torque wrench when assembling your frame. Torque specifications for individual parts on the 4X are listed below, as well as in the step by step assembly instructions later in the manual. For general bicycle maintenance please consult the torque specifications of the manufacture's component you are adjusting.

KEY TORQUE SPECS

PART NUMBER	DESCRIPTION	TORQUE (IN/LB)
300030110	BOLT TI MALE M6X1X12MM	90-95
300030056	BOLT CAP M3X0.5X12MM	20-25
300030010	BOLT CAP M5X0.8X16MM	90-95
300030196	BOLT CAP M5X0.8X24MM	90-95

SHOCK SETUP

YETI TIPS

Inspect your shock for any visible damage. If oil is leaking or you notice any damage to the surfaces or seals, please contact the Fox Racing Shox service center for repair at 800.FOX.SHOX.

Shock set-up can fluctuate greatly based on the rider. The set-up guide is intended as a base line to get the rider started. Experiment with your settings to find the set-up that works best for you.



TOOLS NEEDED

- Shock Pump
- Tape Measure



01. AIR PRESSURE

The main air spring controls the sag of the shock. For the 4X to ride properly it is important to setup the shock with the correct amount of sag. The 4X works best with 10-15 % (4MM-6MM) of shock sag. To increase the sag reduce the main spring air pressure. To reduce the sag increase the main spring air pressure.



02. SAG

Once you have set your baseline air pressure you need to measure the sag. To measure the sag slide the travel indicator (O-Ring) up against the shock body. With a friend supporting the bike, sit on the saddle (do not bounce) and allow your body weight to compress the shock. Once you have compressed the shock, get off the bike and measure the distance between the shock body and the new position of the travel indicator (O-Ring). This is your sag.



03. PRO PEDAL

The pro-pedal dampening has four levels of adjustment and is controlled by the blue lever and the numbered black dial. Use each setting to adjust the shock for different riding conditions and situations. For example, use propedal for riding to the top of the mountain and then switch to open for the descent. The four different levels of dampening on the shock are: (0) open, (1) light, (2) medium, and (3) firm pro-pedal. If the bike feels too firm, put it on a light setting, and if it feels too sluggish, turn it to the stiffer setting. We have found that the 4X rides best with the pro-pedal in the open or light settings.



SHOCK SETUP



04. REBOUND

The rebound adjustment has 12 clicks of adjustment. The rebound knob is the red adjustment dial located above your blue pro-pedal adjustment lever. As a general rule, adjustments that are too fast (counter-clockwise adjustment) will produce a springy ride with excessive kick-up of the rear end causing a bucking sensation. Adjustments that are too slow (clockwise adjustment) will cause packing of the rear wheel indicated by a sluggish ride feeling ride.

Slower rebound- turn the knob clockwise
Faster rebound- turn the knob counter-clockwise

QUICK START GUIDE - RP23

ADJUSTMENT	SETTING
AIR SPRING SETTING (PSI)	EQUAL TO RIDER WEIGHT
MEASURED SAG (MM)	4-6
REBOUND	*5 CLICKS
PRO-PEDAL LEVER	OPEN
PRO-PEDAL KNOB	POSITION 0

**All clicks are counted clockwise, rotating from the all the way out or counter - clockwise dial position.*

CABLE SETUP

YETI TIPS

The 4X has full cable housing. By using full cable housing, we have eliminated break points in the line of your shifter housing. This allows riders to experience better overall shifting performance by reducing the entrance of unwanted elements such as sweat and sediment. Use of full cable housing helps prevent corrosion from the elements and keeps the shifting smoother for a longer period of time.

Caution: The failure to properly route shifter housing can cause malfunction of the shift mechanism and unexpected shifting of gears.



01. REAR DERAILLEUR

Fit the housing from the rear shifter across the head tube and across the two cable guides on the underside of the down tube. Next, route the cable around the dogbone and into the two cable guides on the drive side seat stay and into the derailleur to finish.



02. REAR BRAKE

The rear brake line loops across the head tube and into the three cable stops on the down tube. Next, route the brake line over the bottom bracket shell and across the non-drive chainstay. Ensure the line is finished on the inside of the seatstay when attached to the caliper body. This will prevent the brake line from being compromised if the bike or rider falls.



ASSEMBLY

YETI TIPS

Make sure your tools are in good condition. A worn allen key can round the hex on a bolt not allowing for proper torque.

Torque settings are listed throughout the instructions. It is also important to prep all bolt threads. The instructions denote whether to use a blue Loctite compound or grease.

Warning: Service on Yeti bicycles requires special knowledge and tools. Yeti Cycles recommends that all service and repairs be performed by an authorized Yeti Dealer

TOOLS NEEDED

- Dead blow hammer
- 6mm allen key
- Two - 5mm allen keys
- 2.5mm allen key
- Guide pin tool
- Grease
- Blue loctite



01.

Install four M3x0.5x12 mm bolts prepped with blue loctite into the dogbone with a 2.5mm allen key.

Torque to 20-25 in/lb.



02.

Press two 22.0mm reducers into the lower portion of the shock.



03.

Install the shock on the frame. Insert a 31.0mm Ti female bolt through the drive side of the frame for the shock. Prep an alloy male bolt with blue loctite and tighten with two 5mm allen keys.

Torque to 90-95 in/lb.



04.

Install the dogbone onto the frame. Insert a 31.0mm Ti female bolt with washer through the drive side of the frame and the dogbone. The fox guide pin tool and a dead blow hammer can be used help guide any female bolts through the frame and its components. Use a Ti male bolt prepped with blue loctite on the non-drive side and tighten with two 5mm allen keys.

Torque to 90-95 in/lb.





05.

Align the shock and dogbone. Orient the lower portion of the shock between the lower bearings on the dogbone.



06.

Slide the swingarm over the main pivot bore, using the grooves in the swingarm to properly align over the bore.



09.

Attach the seat stays to the chain stays. The inside of the seat stays should be flush with the shoulders of the bearings on the chain stays. Insert a 16.5mm Ti female bolt through the drive side of the junction and tighten with a Ti male bolt prepped with blue loctite using two 5mm allen keys. Repeat the process on the opposite side.

Torque to 90-95 in/lb.



10.

Prep an M6x12mm male Ti bolt with blue loctite and install into the 53.0mm Ti stud.



07.

Prep the main pivot pin (shaft) with grease. Install the female pivot pin from the drive side of the bike. Use a dead blow hammer to push the pin into place. Once in place, install and tighten with a Ti male bolt prepped with blue loctite and a Yeti custom washer using a 5mm and 6mm allen key.

Torque to 90-95 in/lb.



08.

Prep the two M5x0.8x16 mm cap bolts with blue loctite and tighten into the M5 barrel inserts on the back of the chain stays by the seat stay junction.

Torque to 90-95 in/lb.



11.

Use the fox guide pin tool and a dead blow hammer to install the assembly created in step 9 through the seatstays, dogbone, and shock. Use a Ti male bolt prepped with blue loctite on the non-drive side and tighten with two 5mm allen keys.

Torque to 90-95 in/lb.



12.

Prep the two M5x0.8x24 mm cap bolts with blue loctite and tighten into the M5 barrel inserts on the front of the chain stays by the main pivot junction.

Torque to 90-95 in/lb.

EXPLODED VIEWS

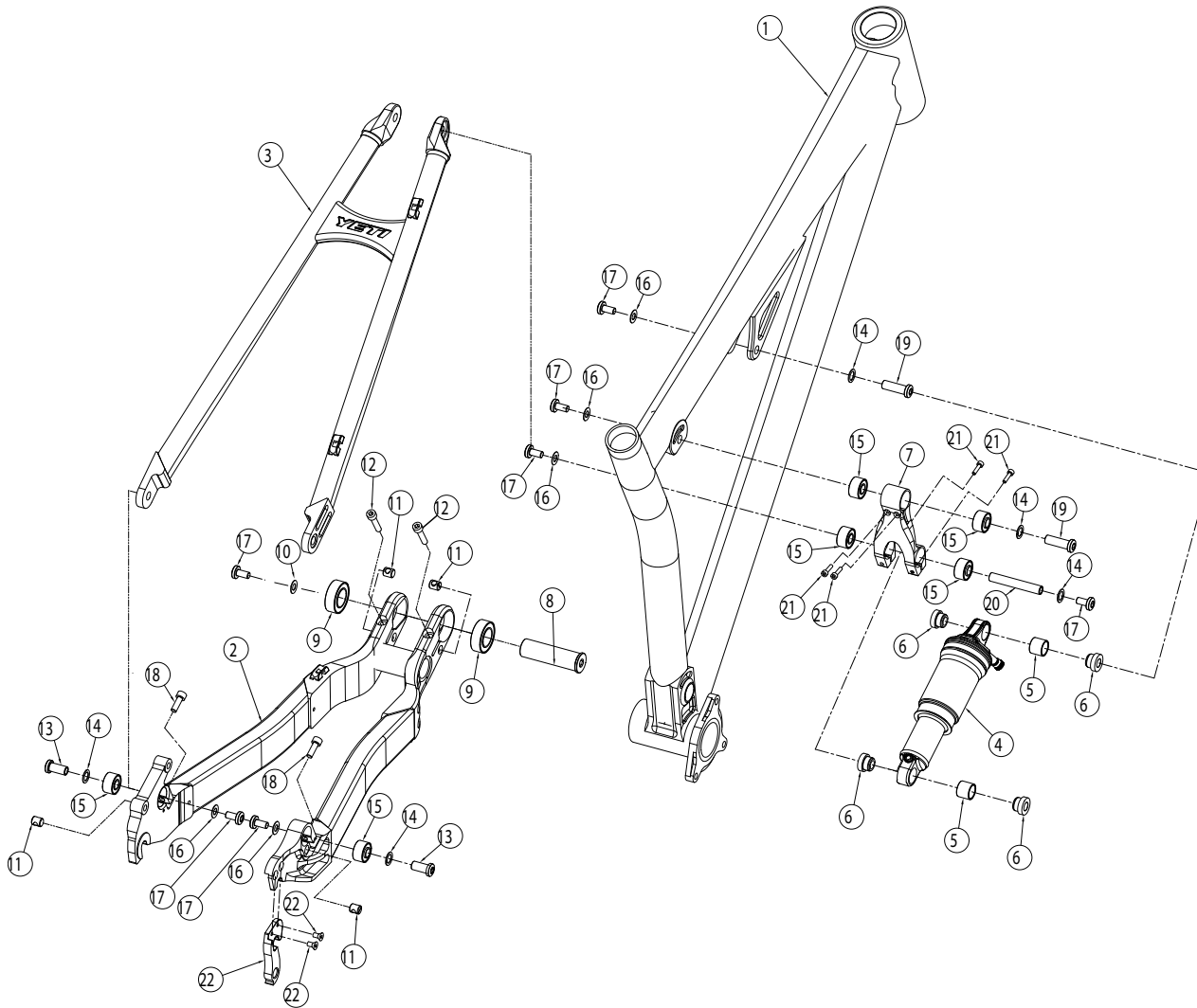

	PART #	DESCRIPTION	QTY
1	NA	FRONT TRIANGLE 4X	1
2	NA	CHAINSTAY 4X	1
3	NA	SEATSTAY 4X	1
4	NA	FOX RP23 [6.5"X1.5"]	1
5	300020020	GARLOCK DP BUSHING .5"X.5"	2
6	300020034	REDUCER FOX 8X22MM	4
7	300040228	4X DOGBONE	1
8	300030115	PIVOT PIN 17X7.5/10X1THRD 58.5	1
9	300020030	BEARING 3903 2RS MAX	2
10	300030179	WASHER-CUSTOM PIVOT PIN-7075	1
11	300040349	BARREL INSERT M5	4
12	300030196	BOLT CAP M5X0.8X24 MM	2
13	300030114	BOLT-TI-FEMALE 8.0X16.5MM	2
14	300030069	WASHER 8.5X12.5X0.5 MM	5
15	300020032	BEARING 398 2RS MAX DOUBLE ROW	6
16	300030062	WASHER 6.5X12.5X0.5 MM	5
17	300030110	BOLT-TI-MALE M6X1.12 MM	7
18	300030010	BOLT CAP M5X0.8X16 MM	2
19	300030186	BOLT-TI-FEMALE 8.0X31MM	2
20	300030187	STUD-TI-FEMALE 8X53MM	1
21	300030056	BOLT CAP M3X0.5X12 MM	4
22	300060045	DERAILLEUR HANGER W/FASTENERS	1

REBUILD KITS

PART #	DESCRIPTION	QTY
200020097	4X '06-'12 MASTER REBUILD KIT	1
	300020030 BEARING 3903 2RS MAX	2
	300020032 BEARING 398 2RS MAX DOUBLE ROW	6
	300030056 BOLT CAP M3X0.5X12 MM	4
	300030114 BOLT-TI-FEMALE 8.0X16.5MM	2
	300030110 BOLT-TI-MALE M6X1 12 MM	7
	300030186 BOLT-TI-FEMALE 8.0X31MM	2
	300030115 PIVOT PIN 17X7.5/10X1THRD 58.5	1
	300020034 REDUCER FOX 8X22MM	4
	300030187 STUD-TI-FEMALE 8X53MM	1
	300030062 WASHER 6.5X12.5X0.5 MM	5
	300030069 WASHER 8.5X12.5X0.5 MM	5
	300030179 WASHER-CUSTOM PIVOT PIN-7075	1
	300030056 BOLT CAP M3X0.5X12 MM	4
200020098	4X '06-'12 BEARING REBUILD KIT	1
	300020030 BEARING 3903 2RS MAX	2
	300020032 BEARING 398 2RS MAX DOUBLE ROW	6
200020117	4X '06-'12 HARDWARE KIT	1
	300030110 BOLT TI MALE M6X1X12MM	7
	300030186 BOLT-TI-FEMALE 8.0X31MM	2
	300030187 STUD-TI-FEMALE 8X53MM	1
	300030115 PIVOT PIN 17X7.5/10X1THRD 58.5	1

	300030062	WASHER 6.5X12.5X0.5 MM	5
	300030069	WASHER 8.5X12.5X0.5 MM	5
	300030114	BOLT-TI-FEMALE 8.0X16.5MM	2

WARRANTY

YETI LIMITED (1) ONE YEAR FRAME WARRANTY

(applies to 303 WC / 4X / DJ)

Yeti Cycles will repair or replace, at its option, any frame it determines to be defective due to defective materials and/or workmanship. The (1) one year limited warranty is conditioned upon the bicycle being ridden under normal conditions and having been properly maintained. This warranty does not apply to the components attached to the frameset such as suspension components, wheels, drive train, brakes, seatpost, handlebar and stem. This warranty applies only to the original owner and is non-transferable. This warranty is void if the bicycle was not properly assembled by an authorized Yeti dealer.

YETI LIMITED (2) TWO YEAR FRAME WARRANTY

(applies to AS-R 5C / AS-R 5A / AS-R Carbon / SB66-A / SB66-C / SB95 / 575 / ARC / Big Top 29'R)

Yeti Cycles will repair or replace, at its option, any frame it determines to be defective due to defective materials and/or workmanship. The (2) two year limited warranty is conditioned upon the bicycle being ridden under normal conditions and having been properly maintained. This warranty does not apply to the components attached to the frameset such as suspension components, wheels, drive train, brakes, seatpost, handlebar and stem. This warranty applies only to the original owner and is non-transferable. This warranty is void if the bicycle was not properly assembled by an authorized Yeti dealer.

ADDITIONAL CONDITIONS

These limited warranties do not apply to normal wear and tear, nor to claimed defects, malfunctions or failures that result from abuse, neglect, improper assembly, improper maintenance, alteration, collision, crash or misuse. The original owner shall pay all labor charges connected with the repair or removal of all components. Under no circumstance does this limited warranty include the cost of travel or shipment to and from an authorized Yeti dealer. In order to exercise your rights under these limited warranties, the bicycle or frameset must be presented to an authorized Yeti dealer, together with proof of purchase.

**The above warranties have been in effect since January 2012. For warranty information on Yeti frames sold prior to that date please consult your local authorized dealer.*

NO FAULT REPLACEMENT POLICY

Yeti Cycles will make replacement parts available at a minimum charge to the original owner in the event of a crash or any other non-warranty situation. Yeti Cycles does this at its sole discretion and reserves the right to refuse this offer.

PRODUCT LIFE CYCLE

Every YETI frameset has a useful product life cycle. The length of that useful product life cycle will vary depending on the construction and the materials of the frameset, maintenance and care the frameset receives, and the amount and type of use the frameset is subjected to over its life. YETI recommends that an authorized YETI dealer should inspect the frame for stress annually. Frame stress could cause potential failure and the signs are usually apparent in the form of cracks, fracture lines, deformation, dents, and any other visual indicators of abnormality. These safety checks for frame stress are important to prevent accidents, injury to the cyclist, and product failure of a YETI frameset.

DISCLAIMER

YETI Cycles is not responsible for any damages to you or others arising from riding, transporting or other use of your bicycle. In the event that your frame breaks or malfunctions, YETI Cycles shall have no liability or obligation beyond the repair or replacement of your frame pursuant to the terms outlined in the warranty.

**If you have a warranty concern, please contact your authorized Yeti dealer.*

YETI CYCLES

600 Corporate Circle, Unit D
Golden, CO 80401
(p) 303-278-6909
(f) 303-278-6906
www.yeticycles.com

BUSINESS HOURS

Monday-Friday
8AM-11:30AM, 1:00PM-5:30PM
(Mountain Time)